

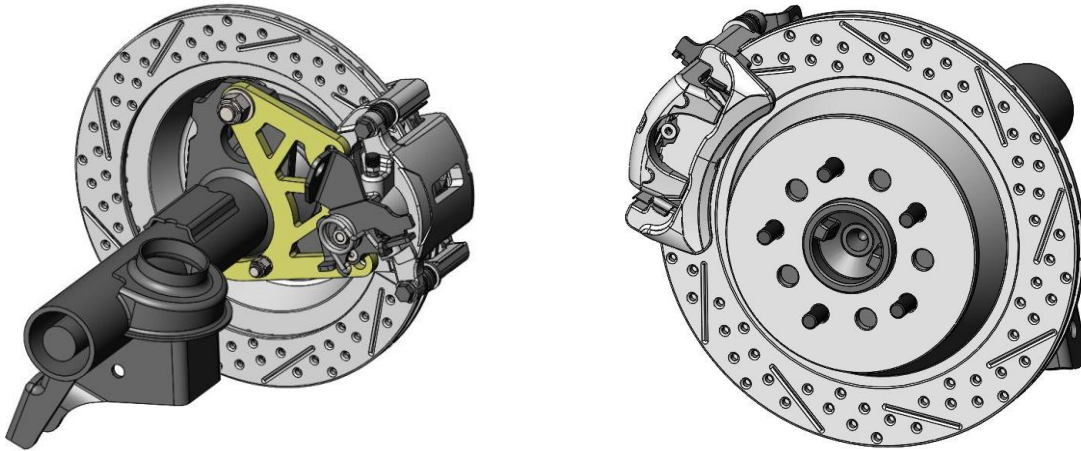

Master Power Brakes 13" Rear Disc Brake Conversion Kit

82-92 Chevrolet/GMC S10 Trucks,
82-92 GM F-Body (with 10-Bolt Rear Axles)

P/N: DB3770BR



Actual Axle Housing May Vary – Visual Representation Only

Thanks for your purchase of our Legend HP Plus Series Rear Disc Brake Conversion Kit for 82-92 Chevrolet/GMC S10 Trucks and 82-92 GM F-Body's with 10-Bolt Rear Axles. This system does require modifications to the rear axle housing flanges and uses basic hand tools to install. The system is designed to take place of your current drum brake system and replace it with a simple disc brake system.

Installation Notes:

- Please read all instructions before attempting the installation.
- Proper operation of your brakes is essential for your safety and the safety of others. Any brake service should be performed by a professional technician experienced in the installation of brake systems.
- Any installation requiring you to remove a wheel or gain access under the vehicle requires use of jack stands or a lift appropriate to the weight of the vehicle. In all cases, recommended ratings for jack stands should be at least 2-tons. If using a floor jack, be sure to use the appropriate wheel chocks.
- All installations require proper safety procedures and protective eyewear.
- A selection of hand tools sufficient to engage in the installation of these products is assumed and is the responsibility of the installer to have in his/her possession prior to beginning this installation. All installations, which require removal of hydraulic hoses and/or bleeding of the brakes, require appropriate fitting/line wrenches, as well as a safety catch can and protective eyewear. Other than these items, if unique or special tools are required, they are listed in the section for that step.
- **ALWAYS CONFIRM WHEEL FITMENT PRIOR TO BEGINNING THE INSTALLATION OF ANY BRAKE SYSTEM!!** Returns will not be accepted for ANY installed part or assembly. Use great care to prevent cosmetic damage when performing wheel fit check!
- Before starting the installation, verify that all parts are included with the brake kit. If items are missing, notify Master Power Brakes immediately.
- Master Power Brakes recommends the use of a high-quality DOT 3 or DOT 4 brake fluid. **ALL WARRANTY IS VOID IF DOT 5 FLUID IS USED.**

If you have any questions regarding installation, feel free to contact Master Power Brakes at (888) 351-8781 or through our website at www.mpbrakes.com.

Parts List	
Quantity	Description
1	Driver Side Caliper (Includes Caliper Anchor Bracket)
1	Passenger Side Caliper (Includes Caliper Anchor Bracket)
1	Brake Pad Set
1	Left Brake Rotor (Slotted, Drilled, & Zinc Washed)
1	Right Brake Rotor (Slotted, Drilled, & Zinc Washed)
2	Primary Caliper Mounting Bracket
4	Stainless Steel Brake Pad Abutment Clips
4	M12-1.75 x 35mm Hex Head Screws
4	M12 Flat Washers
2	9/16"-18 x 1.750" Grade 8 Hex Head Bolt
2	9/16"-18 Nylon Lock Nuts
4	9/16" SAE Flat Washers
4	3/8"-24 x 1.500" Grade 8 Hex Head Bolt
4	3/8"-24 Nylon Lock Nuts
8	3/8" AN Flat Washers
1	Hose Kit (8" Hoses w/10mm Banjo Bolt & Hardware)

Replacement Parts	
Brake Pads	FMSI No: 1082

Installation:

1. With the vehicle properly supported, remove the rear wheels and tires.
2. Removal of the factory drum brake assembly is required next. With the brake drum removed, remove the axle shafts from the axle housing along with any remaining drum brake components such as the shoes and backing plates.
3. At this time, clean the axle shaft thoroughly and inspect the axle bearings and axle housing for any excessive wear.
4. The outer diameter of the axle flange can be no larger than 6.875" in outside diameter. This is critical for proper fitment of the rotor over the axle flange. For axles with a flange larger than 6.875", using a lathe, machine the outer flange down to the necessary diameter of 6.875". See Figure 1 below for measuring reference.

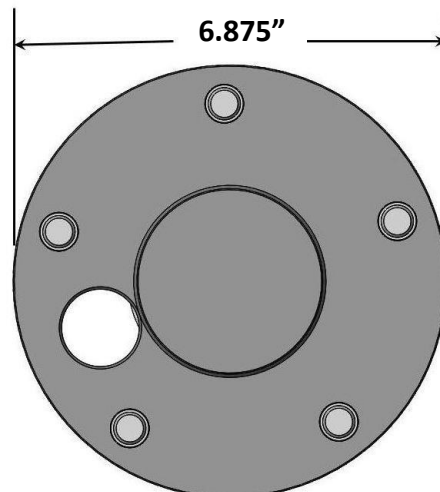

Figure 1 – Measuring the Axle Flange

5. Drill the lower two threaded holes in the axle housing flange to 3/8". Using a 3/8" drill bit, drill the lower two threaded bolt holes to allow fitment of the new mounting hardware. Make sure you deburr the edges of the holes after you drill them so that the mounting hardware and Caliper bracket set flat. Refer to figures 2a and 2b below for reference on drilling the holes.

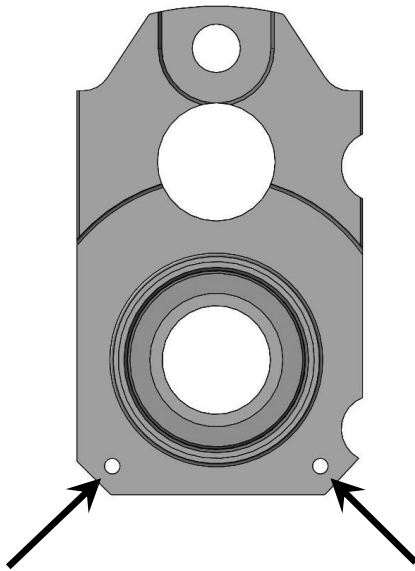

Figure 2a – Hole Modification Location

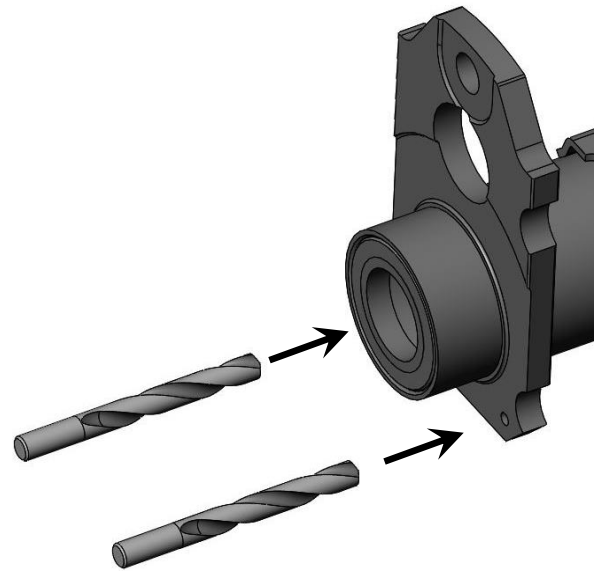

Figure 2b – Open Holes Up To 3/8"

6. Reinstall the axle shafts back into the axle housing.
7. Install the Primary Caliper Mounting Bracket using the supplied 9/16"-18 x 1.750" Grade 8 Hex Head Bolts in the upper drum brake pivot hole. Use the supplied 9/16" SAE Flat Washers. Loosely install the 9/16"-18 Nylon Lock Nuts. Install the supplied 3/8"-24 x 1.500" Grade 8 Hex Head Bolts, 3/8" AN Flat Washers, and 3/8"-24 Nylon Lock Nuts in the two lower holes. With all hardware started, torque the 9/16" hardware to 100lb/ft and the 3/8" hardware to 35ft/lb. **NOTE:** Install the caliper bracket so that it will position the caliper to the rearward side of the axle housing. Refer to Figure 3 below for installation reference.

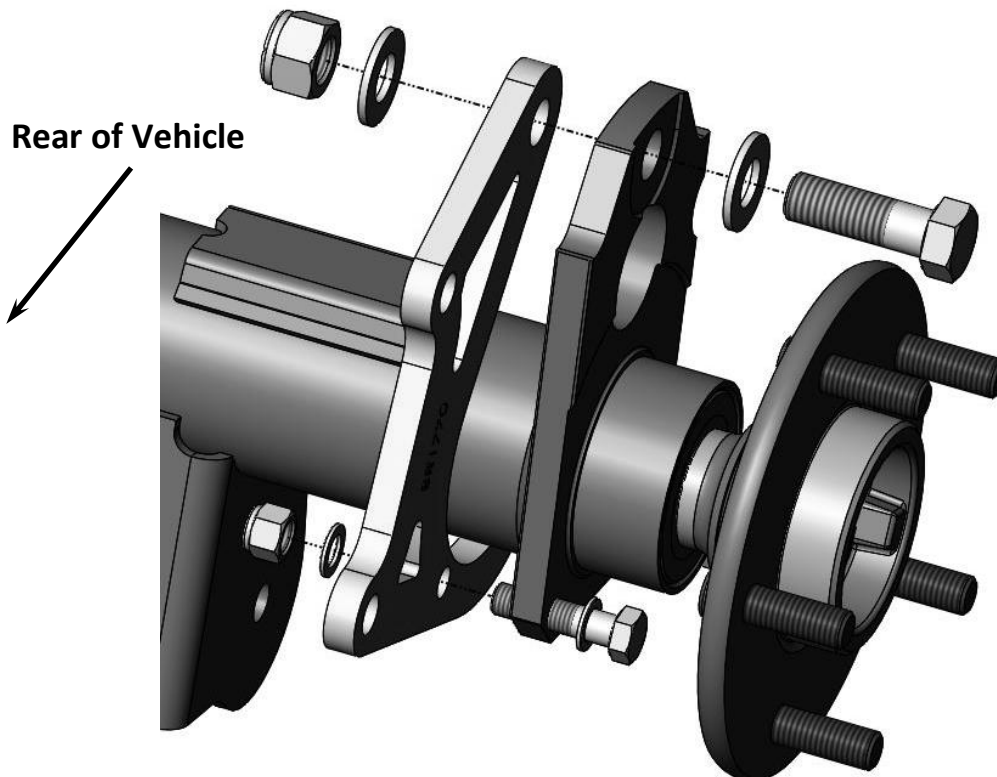

Figure 3 – Axle Re-installed w/Primary Caliper Mounting Bracket Installation (Passenger Side Shown)

8. Install the rotor onto the axle flange. Verify that the rotor goes all the way against the axle flange. See Figure 4a for reference. **TIP:** To make caliper installation easier, thread a couple of flatwashers and nuts against the rotor to act as a lug nut and hold everything in place. **IMPORTANT:** If using slotted and drilled rotors, pay close attention to Figure 4b below for proper rotor placement on the driver and passenger side.

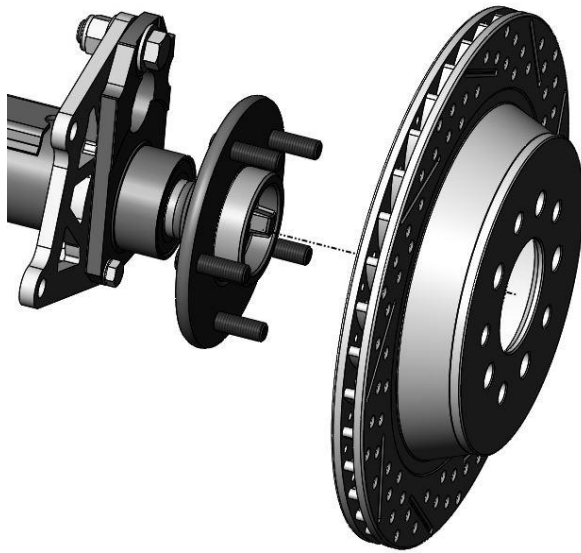

Figure 4a – Rotor Installation

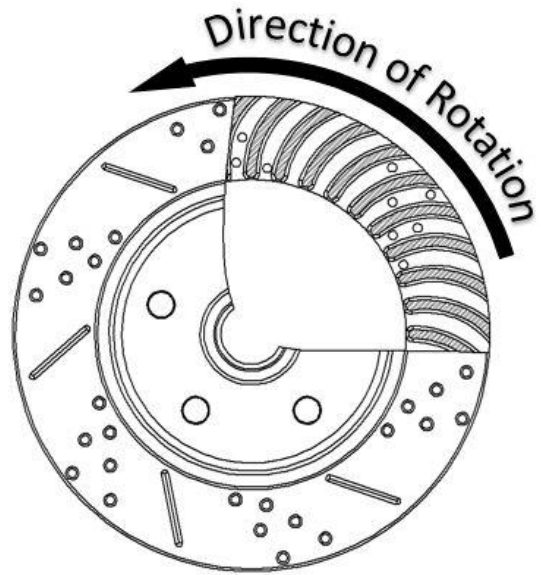

Figure 4b – Rotor Orientation

9. Remove the Caliper Anchor bracket from the caliper by removing the M8-1.25 x 21mm Caliper Mounting Bolts from the cast-iron Anchor Bracket. Install the Caliper Anchor Bracket over the rotor. Using the provided M12 Flat Washers and M12-1.75 x 35mm Socket Head Cap Screws, install and torque the bolts to 80 lb/ft. Refer to Figure 5 below for reference on installing the caliper anchor and location of the spacer.

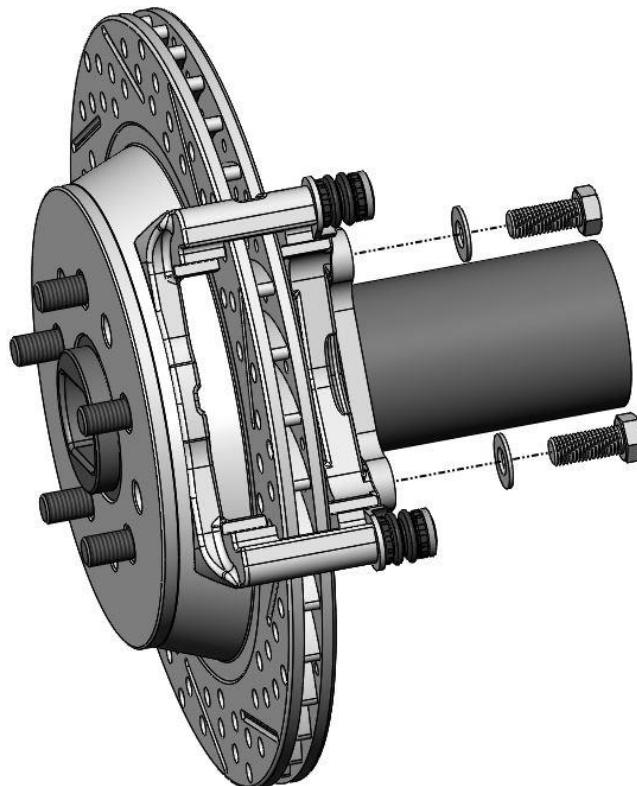

Figure 5 – Caliper Anchor Installation

10. Place the Stainless-steel Abutment Clips into the Caliper Anchor Bracket at this time. Refer to Figure 6a and Figure 6b Below for installation reference.

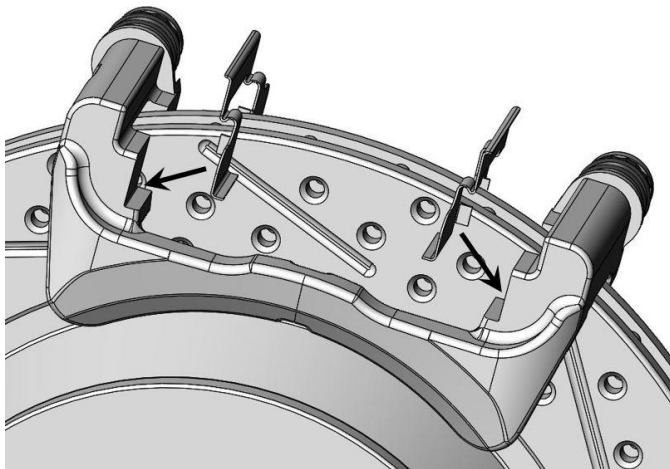

Figure 6a – Abutment Clips Installation

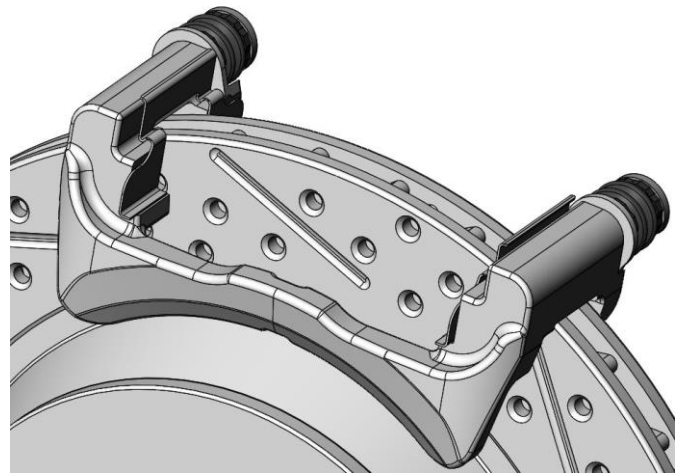

Figure 6b – Abutment Clips Installed

11. With the Abutment Clips installed, position the pads into the Caliper Anchor Bracket. Refer to Figure 7a below for reference. Once the pads are installed slide the caliper body over the brake pads and Caliper Anchor Bracket. With the caliper in place, re-install the caliper mounting bolts between the caliper and the bracket. Torque the bolts to 30 lb/ft. **IMPORTANT:** Make sure that the bleeder screw is pointing upward. See Figure 7b below for reference on installing the caliper.

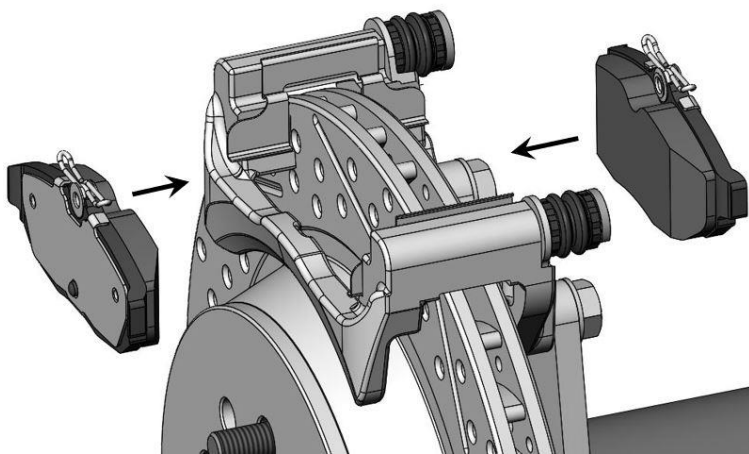

Figure 7a – Brake Pad Installation

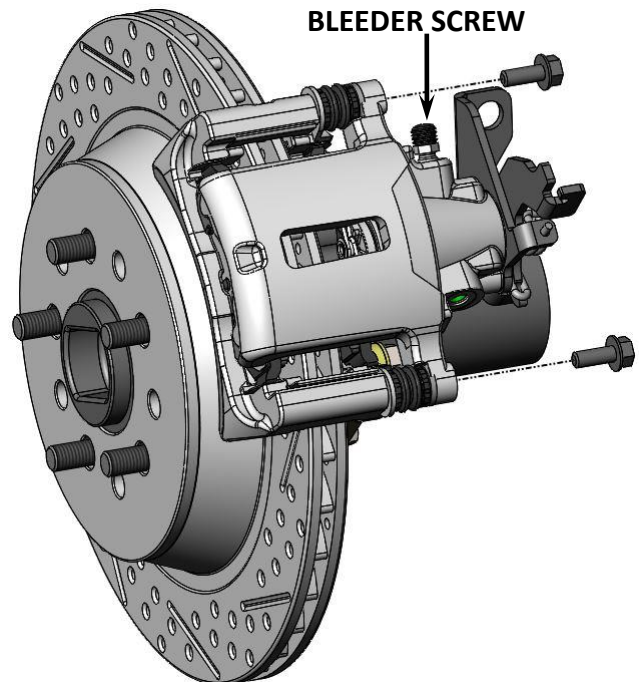

Figure 7b - Caliper Installation and Bleeder Screw Orientation

12. Install the flexible brake hose. Attach the brake hose to the caliper using the provided banjo bolt and copper crush washers as shown in Figure 8a on the next page. Fasten the “L” shaped brackets onto the axle housing. This can be done with large worm style clamps like shown on the next page in Figure 8b or by welding or bolting. Once the brackets are installed, use the provided clip and attach the brake hose to the bracket. Attach the hardline to the brake hose. It may be necessary to shorten and re-flare the hardline.

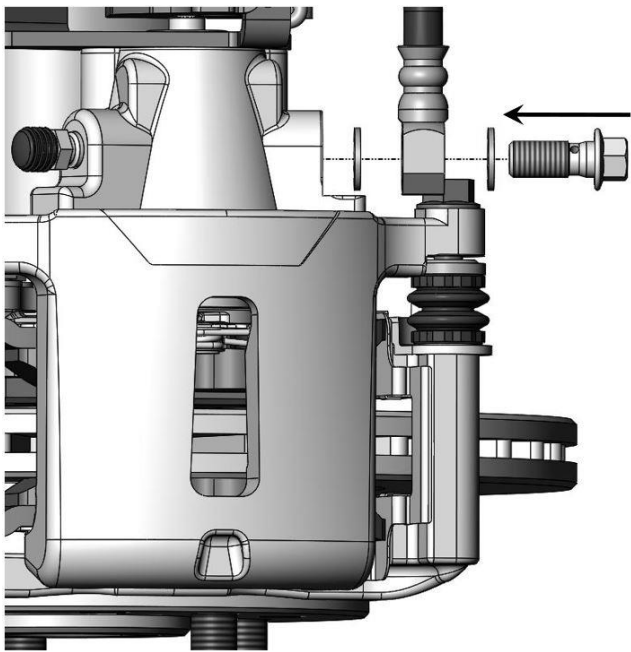
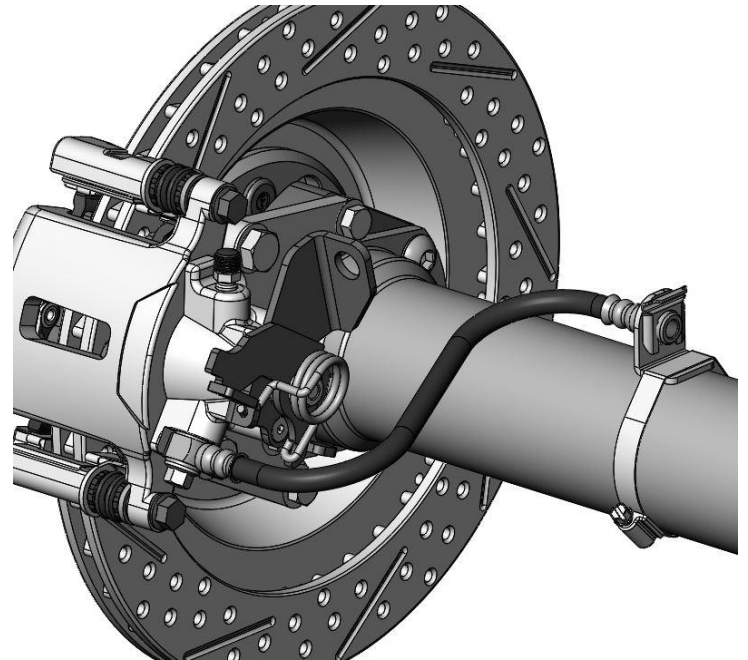

Figure 8a – Brake Hose Attachment to Caliper



**Figure 8b – Brake Hose Attached at the Rear Axle Housing
(Picture is for reference only and may not reflect actual installation)**

13. Once the caliper has been installed and everything is torqued to spec, it is recommended that the caliper be adjusted before installing any emergency brake cables. To do so, simply rotate the park brake lever on the caliper a couple of times. This will move the brake pads closer to the rotor and allow for adequate movement along with a proper feeling pedal.
14. With the caliper adjusted, attach the emergency brake to the caliper. If using the Master Power Brakes Universal Emergency Brake Cable Kit (p/n: HWC2500) shown below in Figure 9, please follow the instructions included with the cables. If obtaining cables from a different source, please follow the instructions for those cables. Once the cables are installed, verify that there isn't excessive drag caused by the cables and caliper adjustment. Also, please verify that there isn't excessive movement or travel within the cables.



Figure 9 – Universal Emergency Brake Cable Kit (p/n: HWC2500)

15. Once everything is installed and pre-adjustments have been made, bleed the brakes and re-install the wheels and tires.
16. Installation is now complete.

If you have any questions or comments, please call Master Power Brakes at (888) 351-8781.