

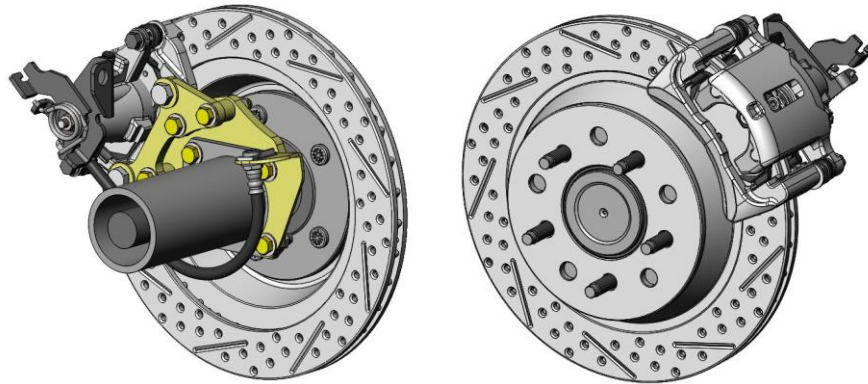

# MASTER POWER BRAKES



## 13" Rear Disc Brake Conversion Kit 62-87 GM ½ Ton 2wd Trucks P/N: DB3793BR



Thanks for your purchase of our Legend HP Plus Series Rear Disc Brake Conversion Kit for 62-87 Chevrolet and GMC C/K Trucks. This system does not require modifications to the rear axle flanges and uses basic hand tools to install. The system is designed to take place of your current drum brake system and replace it with a simple disc brake system.

**\*\*\*IMPORTANT\*\*\***

**This kit requires the use of at least 17" wheels for clearance and this kit has a 5 x 5.000" bolt pattern**

### Installation Notes:

- Please read all instructions before attempting the installation.
- Proper operation of your brakes is essential for your safety and the safety of others. Any brake service should be performed by a professional technician experienced in the installation of brake systems.
- Any installation requiring you to remove a wheel or gain access under the vehicle requires use of jack stands or a lift appropriate to the weight of the vehicle. In all cases, recommended ratings for jack stands should be at least 2-tons. If using a floor jack, be sure to use the appropriate wheel chocks.
- All installations require proper safety procedures and protective eyewear.
- A selection of hand tools sufficient to engage in the installation of these products is assumed and is the responsibility of the installer to have in his/her possession prior to beginning this installation. All installations, which require removal of hydraulic hoses and/or bleeding of the brakes, require appropriate fitting/line wrenches, as well as a safety catch can and protective eyewear. Other than these items, if unique or special tools are required they are listed in the section for that step.
- **ALWAYS CONFIRM WHEEL FITMENT PRIOR TO BEGINNING THE INSTALLATION OF ANY BRAKE SYSTEM!!** Returns will not be accepted for ANY installed part or assembly. Use great care to prevent cosmetic damage when performing wheel fit check!
- Before starting the installation, verify that all parts are included with the brake kit. If items are missing, notify Master Power Brakes immediately.
- Master Power Brakes recommends the use of a high quality DOT 3 or DOT 4 brake fluid. **ALL WARRANTY IS VOID IF DOT 5 FLUID IS USED.**

Parts List	
Quantity	Description
1	Driver Side Caliper (Includes brake pads and Caliper Anchor Bracket)
1	Passenger Side Caliper (Includes brake pads and Caliper Anchor Bracket)
1	Left 13" Drilled, Slotted, & Zinc Washed Brake Rotor
1	Right 13" Drilled, Slotted, & Zinc Washed Brake Rotor
2	Primary Caliper Mounting Bracket
2	Secondary Caliper Mounting Bracket
4	M12-1.75 x 30mm Socket Head Cap Screws
4	M12 Flat Washers
8	3/8"-24 x 2.000" Grade 8 Hex Head Bolt
6	3/8"-24 x 1.500" Grade 8 Hex Head Bolt
2	3/8"-24 x 1.250" Grade 8 Hex Head Bolt
16	3/8"-24 Nylon Lock Nut
32	3/8" SAE Flat Washers
8	Spacer Bushing (.375" ID x .750" OD x .500" Thick)
2	Axle Centric Ring
1	Hose Kit (14" Hoses w/10mm Banjo Bolt & Hardware)
1	Left Brake Hose Mounting Bracket
1	Right Brake Hose Mounting Bracket

Replacement Parts	
Brake Pads	FMSI No: 1082

## Installation:

1. With the vehicle properly supported, remove the rear wheels and tires.
2. Removing the factory drum brake assembly is required next. With the drum removed, remove the axle shafts from the axle housing. With the axle shafts removed, remove the remaining drum brake components such as the shoes and backing plates.
3. At this time, clean the axle shaft thoroughly and inspect the axle bearings and axle housing for any excessive wear.
4. The outer diameter of the axle flange can be no larger than 6.875" in outside diameter. This is critical for proper fitment of the rotor over the axle flange. For axles with a flange larger than 6.875", using a lathe, machine the outer flange down to the necessary diameter of 6.875". See Figure 1 below for measuring reference.

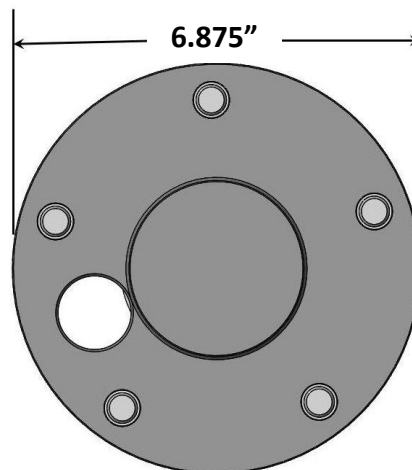

Figure 1 – Measuring the Axle Flange

5. Reinstall the axle shafts back into the axle housing.
6. Install the Primary Caliper Mounting Bracket using the supplied 3/8"-24 x 1.500" Grade 8 Hex Head Bolts, making sure there is a provided 3/8" SAE Flat Washer under each bolt head. See Figure 2a below for determining proper bracket orientation. **Note: The upper forward most bolt goes through the supplied Brake Hose Mounting Brackets top mounting hole.** These brackets are left and right specific and are designed so the tab faces inward to the vehicle. Once everything is in place, loosely secure the bolts with the provided 3/8" SAE Flat Washers and 3/8"-24 Nylon Lock Nuts. **These bolts will be torqued in a later step.** See Figure 2b and Figure 2c below for installation reference.

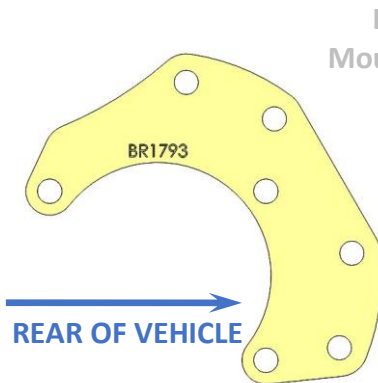

Figure 2a – Primary Caliper Mounting Bracket Orientation

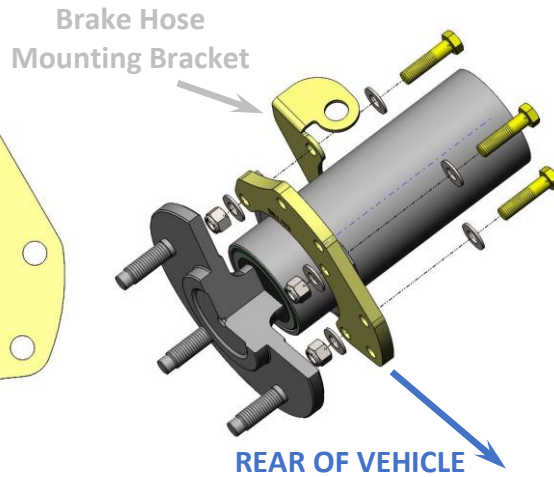

Figure 2b – Primary Caliper Mounting Bracket Installation

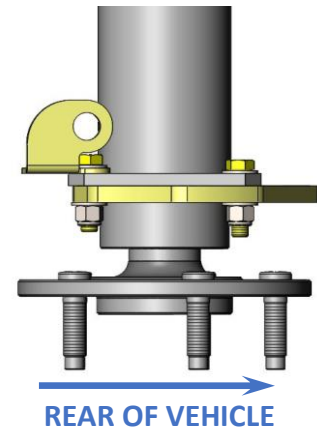

Figure 2c – TOP VIEW Primary Caliper Mounting Bracket Installed

7. Insert the provided 3/8"-24 x 1.250" Grade 8 Hex Head Bolt with a 3/8" SAE Flat Washer under its head through the remaining lower hole on the Brake Hose Mounting Bracket and the axle housing flange. Once installed use a provided 3/8" SAE Flat Washer and a 3/8"-24 Nylon Lock Nut to secure it. At this point this and **ALL** of the 3/8" hardware installed in Step 6 may be torqued to 40 lb/ft. See Figure 3 below for reference.

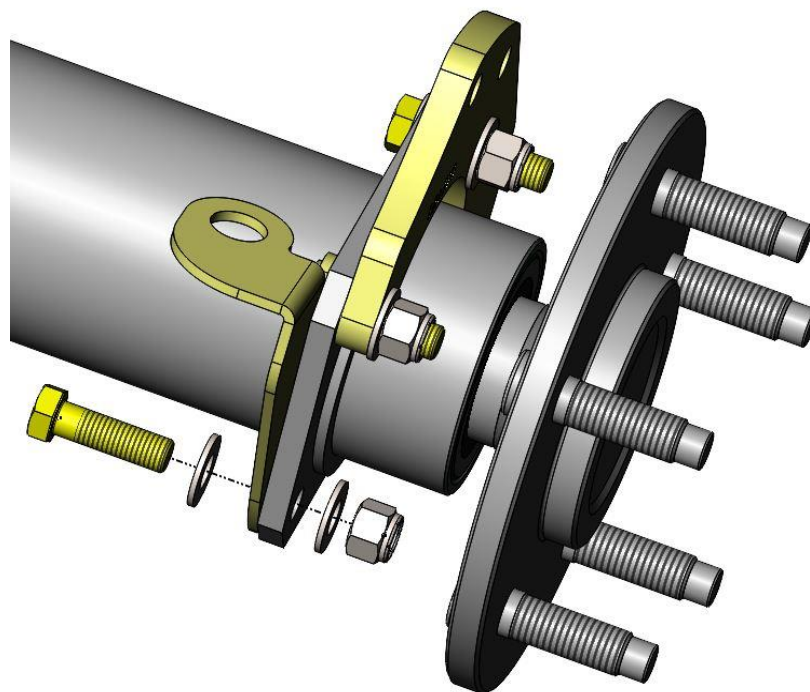

Figure 3 – Lower Brake Hose Mounting Bracket Bolt Installation

8. Using the provided 3/8"-24 x 2.250" Grade 8 Hex Head Bolts, 3/8" SAE Flat Washers, 3/8"-24 Nylon Lock Nuts, and Spacer Bushings, install the Secondary Caliper Mounting bracket to the inboard side of the Primary Caliper Mounting Bracket. The Spacer Bushings install between the Primary and Secondary Brackets. Once in position, install a 3/8" SAE Flat Washers and 3/8"-24 Nyloc Nuts and torque to 40 lb/ft. Figure 4 below shows the bracket installation.

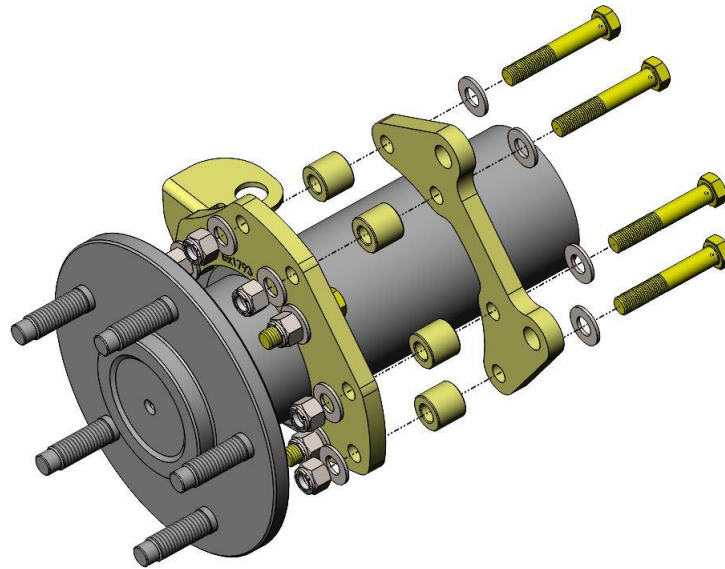

Figure 4 – Caliper Mounting Brackets Installation

9. Install the rotor onto the axle flange. A Centric Ring is provided to center the rotor onto the axle shaft. Place the Centric Ring over the axle hub register. To allow the Centric Ring to go all of the way against the axle shaft flange, it may be necessary to clean the hub register with a wire brush or emery cloth. Once the Centric Ring is in place, slide the rotor over the studs against the axle flange. Verify that the rotor goes all the way against the axle flange. Figure 5a shows the proper sequence. **TIP:** To make caliper installation easier, thread a couple of flatwashers and nuts against the rotor to act as a lug nut and hold everything in place. **IMPORTANT:** If using slotted and drilled rotors, pay close attention to Figure 5b below for proper rotor placement on the driver and passenger side.

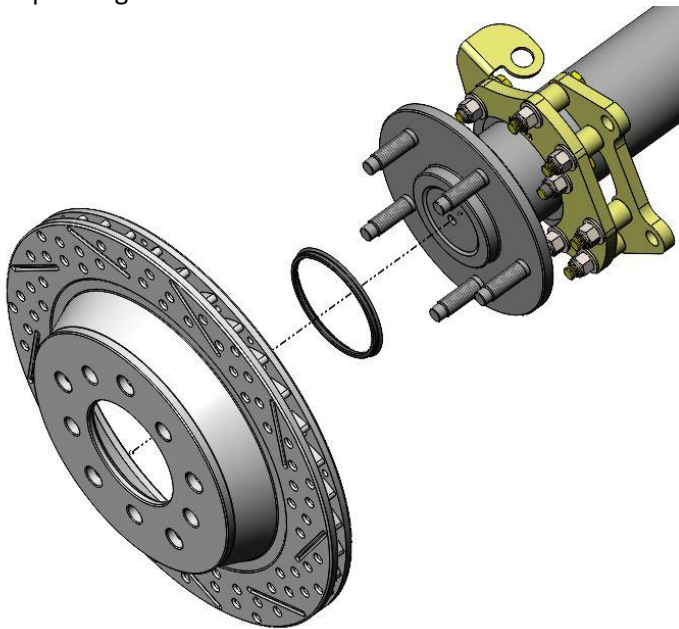

Figure 5a – Rotor and Centering Ring Installation

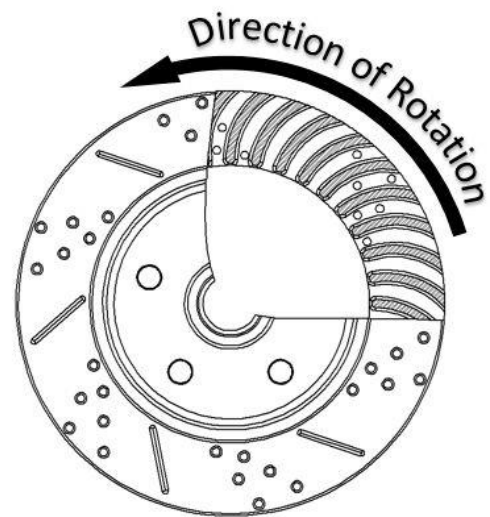

Figure 5b – Rotor Orientation

10. Remove the Caliper Anchor Bracket from the caliper along with the brake pads. Install the Caliper Anchor Bracket over the rotor and position against the Secondary Caliper Mounting Bracket. Use the provided M12 Flat Washers and M12-1.75 x 30mm Hex Head Bolts and torque the bolts to 80 lb/ft. See Figure 6 on the next page for reference.

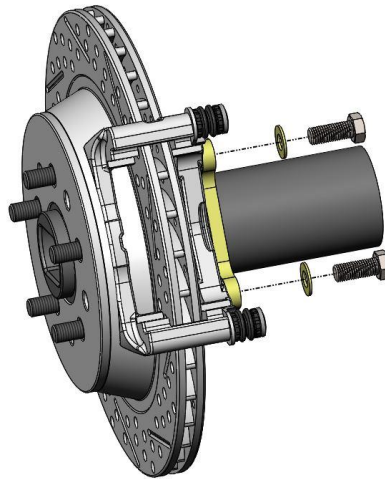

Figure 6 – Caliper Anchor Installation

11. Place the Stainless Steel Abutment Clips into the Caliper Anchor Bracket at this time. Refer to Figure 7a and Figure 7b Below for installation reference.

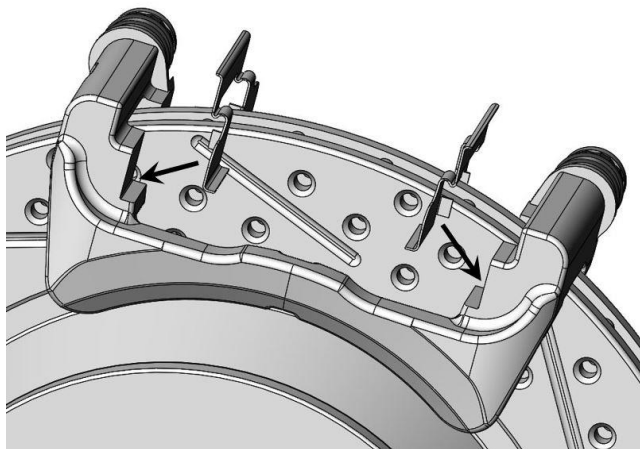

Figure 7a – Abutment Clips Installation

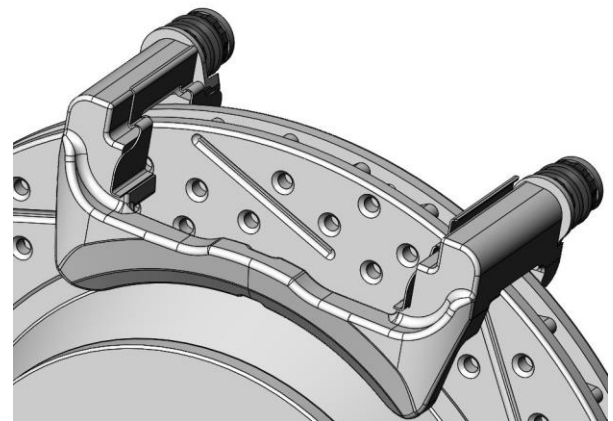

Figure 7b – Abutment Clips Installed

12. With the Abutment Clips installed, install the pads into the Caliper Anchor Bracket. Refer to Figure 8a below for reference. Once the pads are installed slide the caliper body over the brake pads and Caliper Anchor Bracket. With the caliper in place, re-install the caliper mounting bolts between the caliper and the bracket. Torque the bolts to 30 lb/ft. **IMPORTANT:** Make sure that the bleeder screw is pointing upward. See Figure 8b below for reference on installing the caliper.

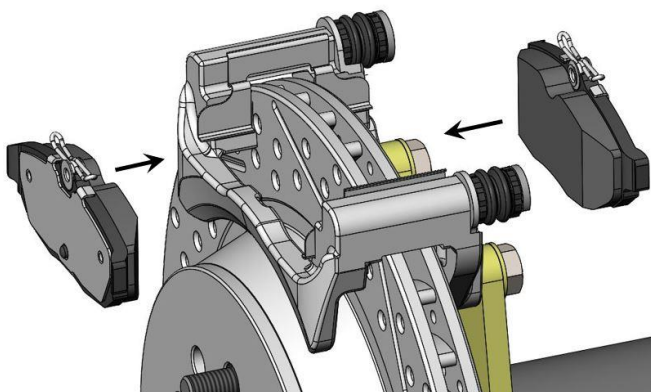

Figure 8a – Brake Pad Installation

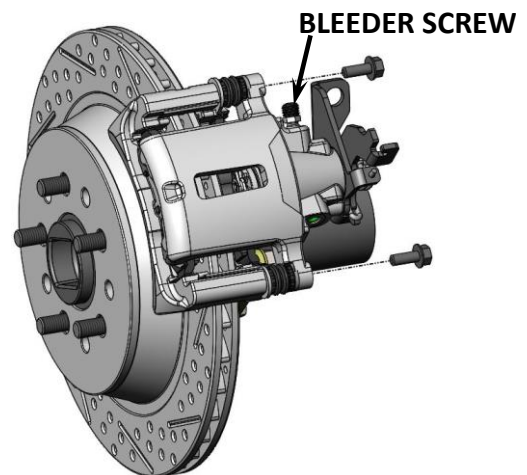

Figure 8b - Caliper Installation and Bleeder Screw Orientation

13. Install the flexible brake hose. Attach the brake hose to the caliper using the provided banjo bolt and copper crush washers as shown in Figure 9a below. Next route the hose under the axle tube and attach it to the previously installed Brake Hose Mounting Bracket with the provided clip. Attach the hardline to the brake hose. **NOTE: Depending on the location and fitting size on the OEM hardline, it may be necessary to shorten and re-flare along with slightly bending the hardline to line up properly.** Proper installation of the flexible brake hose can be seen in Figure 9b below.

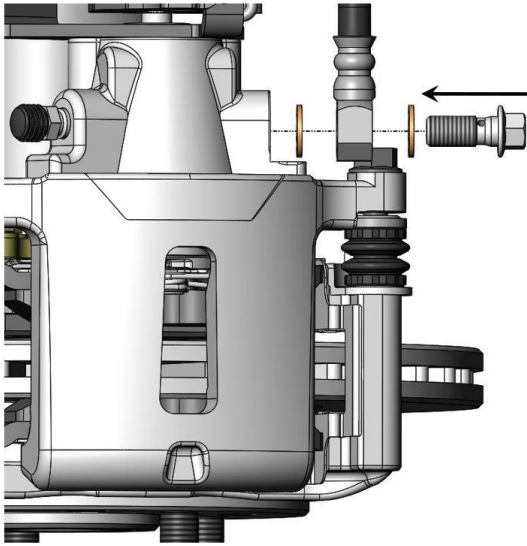

Figure 9b – Brake Hose Attached at the Rear Axle Housing

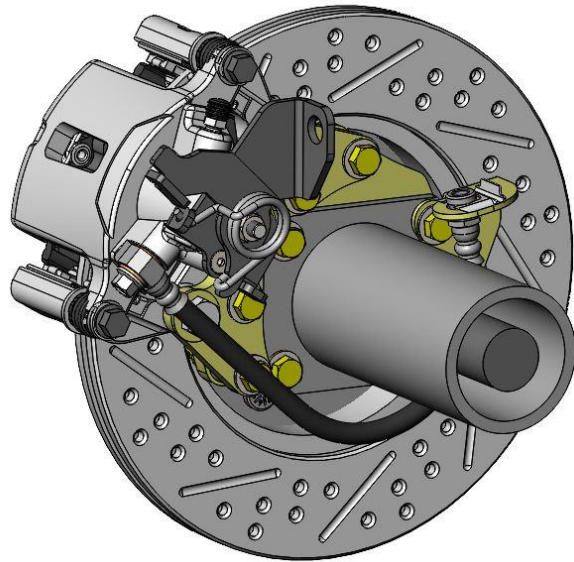

Figure 9b – Brake Hose Attached at the Rear Axle Housing

14. Once the caliper has been installed and everything is torqued to spec, it is recommended that the caliper be adjusted before installing any emergency brake cables. To do so, simply rotate the park brake lever on the caliper a couple of times. This will move the brake pads closer to the rotor and allow for adequate movement along with a proper feeling pedal.
15. With the caliper adjusted, attach the emergency brake to the caliper. If using the Master Power Brakes Universal Emergency Brake Cable Kit (p/n: HWC2500) shown below in Figure 10, please follow the instructions included with the cables. If obtaining cables from a different source, please follow the instructions for those cables. Once the cables are installed, please verify that there isn't excessive drag caused by the cables and caliper adjustment. Also, please verify that there isn't excessive movement or travel within the cables.



Figure 10 – Universal Emergency Brake Cable Kit (p/n: HWC2500)

16. Once everything is installed and pre-adjustments have been made, bleed the brakes and re-install the wheels and tires.
17. Installation is now complete.

If you have any questions regarding installation, feel free to contact us!

 <b>MASTER POWER BRAKES</b> 
<b>PHONE NUMBERS</b>
Local: (704)-664-8866 Toll Free: (888)-351-8781 Fax: (704)-664-8862
<b>WEBSITE</b>
<a href="http://www.mpbrakes.com">www.mpbrakes.com</a>
<b>ADDRESS</b>
110 Crosslake Park Dr. Mooresville, NC 28117
<b>SOCIAL MEDIA</b>
 Instagram @masterpowerbrakes
 facebook <a href="http://www.facebook.com/mpbrakes">www.facebook.com/mpbrakes</a>