



MASTER POWER BRAKES



13" Rear Disc Brake Conversion Kit

55-64 Full Size Chevrolet Cars

P/N: DB3716BR

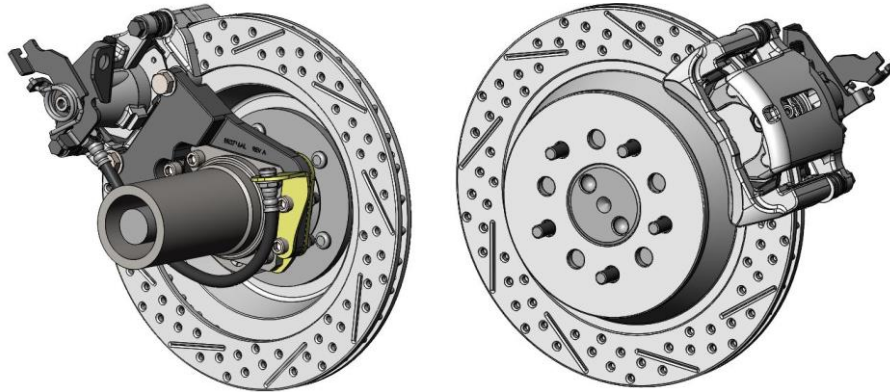

Thanks for your purchase of our Legend Series HP Plus Universal Rear Disc Brake Conversion Kit for the 55-64 Full Size Chevrolet Car rear axles. This system does not require any modifications to the rear axle housing and uses basic hand tools to install. The system is designed to take the place of your current drum brake system and replace it with a simple disc brake system.

*****IMPORTANT*****

This kit requires the use of at least 17" wheels for clearance and this kit has a 5 x 4.750" bolt pattern

Installation Notes:

- Please read all instructions before attempting the installation.
- Proper operation of your brakes is essential for your safety and the safety of others. Any brake service should be performed by a professional technician experienced in the installation of brake systems.
- Any installation requiring you to remove a wheel or gain access under the vehicle requires use of jack stands or a lift appropriate to the weight of the vehicle. In all cases, recommended ratings for jack stands should be at least 2-tons. If using a floor jack, be sure to use the appropriate wheel chocks.
- All installations require proper safety procedures and protective eyewear.
- A selection of hand tools sufficient to engage in the installation of these products is assumed and is the responsibility of the installer to have in his/her possession prior to beginning this installation. All installations, which require removal of hydraulic hoses and/or bleeding of the brakes, require appropriate fitting/line wrenches, as well as a safety catch can and protective eyewear. Other than these items, if unique or special tools are required they are listed in the section for that step.
- **ALWAYS CONFIRM WHEEL FITMENT PRIOR TO BEGINNING THE INSTALLATION OF ANY BRAKE SYSTEM!!** Returns will not be accepted for ANY installed part or assembly. Use great care to prevent cosmetic damage when performing wheel fit check!
- Before starting the installation, verify that all parts are included with the brake kit. If items are missing, notify Master Power Brakes immediately.
- Master Power Brakes recommends the use of a high quality DOT 3 or DOT 4 brake fluid. **ALL WARRANTY IS VOID IF DOT 5 FLUID IS USED.**

Parts List	
Quantity	Description
1	Driver Side Caliper (Includes brake pads and Caliper Anchor Bracket)
1	Passenger Side Caliper (Includes brake pads and Caliper Anchor Bracket)
1	Left 13" Drilled, Slotted, & Zinc Washed Brake Rotor
1	Right 13" Drilled, Slotted, & Zinc Washed Brake Rotor
1	Left Aluminum Caliper Mounting Bracket (Black Anodized)
1	Right Aluminum Caliper Mounting Bracket (Black Anodized)
2	Caliper Bracket Mounting Flange (Gold Zinc Coated)
2	Caliper Bracket Shim Plate (Gold Zinc Coated)
1	Axle Standoff Depth Gauge (Raw Steel)
16	3/8"-24 x 1.500" Socket Head Cap Screw
16	3/8"-24 Nyloc Lock Nut
8	3/8" AN Flat Washer
4	M12 x 35mm Hex Head Bolts
4	M12 Flat Washer
1	Caliper Bracket Shim Kit
1	Hose Kit (14" Hoses w/10mm Banjo Bolt & Hardware)
1	Left Brake Hose Mounting Bracket
1	Right Brake Hose Mounting Bracket

Replacement Parts	
Rear Brake Pads	FMSI No: D1082

Installation:

1. With the vehicle properly supported, remove the rear wheels and tires.
2. Removing the factory drum brake assembly is required next. With the drum removed, remove the axle shafts from the axle housing. With the axle shafts removed, remove the remaining drum brake components such as the shoes and backing plates.
3. At this time, clean the axle shaft thoroughly and inspect the axle bearings and axle housing for any excessive wear. **IMPORTANT: The factory axle retainer must be left on the axle shaft.**
4. The outer diameter of the axle flange can be no larger than 6.875" in outside diameter. This is critical for proper fitment of the rotor over the axle flange. For axle with a flange larger than 6.875", using a lathe, machine the outer flange down to no larger than 6.875". See Figure 1a below for measuring reference. Also the rotor register diameter is 2.780". If your axle register is larger than 2.775", you will need to machine it to 2.775" so that the rotor fits properly and is hub centric. See Figure 1b below for measuring reference.

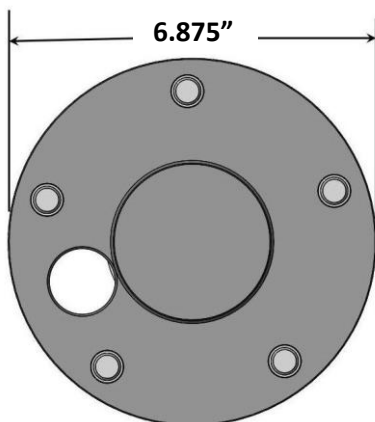

Figure 1a – Measuring the Axle Flange

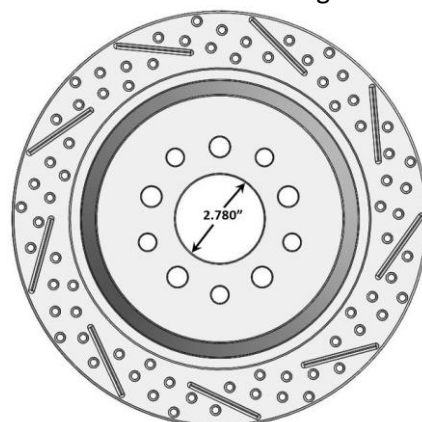

Figure 1b – Rotor Register Diameter

5. Insert the supplied 3/8"-24 x 1.500" Socket Head Cap Crews into the axle housing. Once installed, position the Caliper Bracket Mounting Flange over the bolts and against the axle housing flange. Follow this by reinstalling the axle back into the axle housing, placing the factory bearing retainer over the installed bolts and securing it with the supplied 3/8"-24 Nylon Lock Nuts. Torque all of this mounting hardware to 40 lb/ft. Refer to Figures 2a and 2b below for reference.

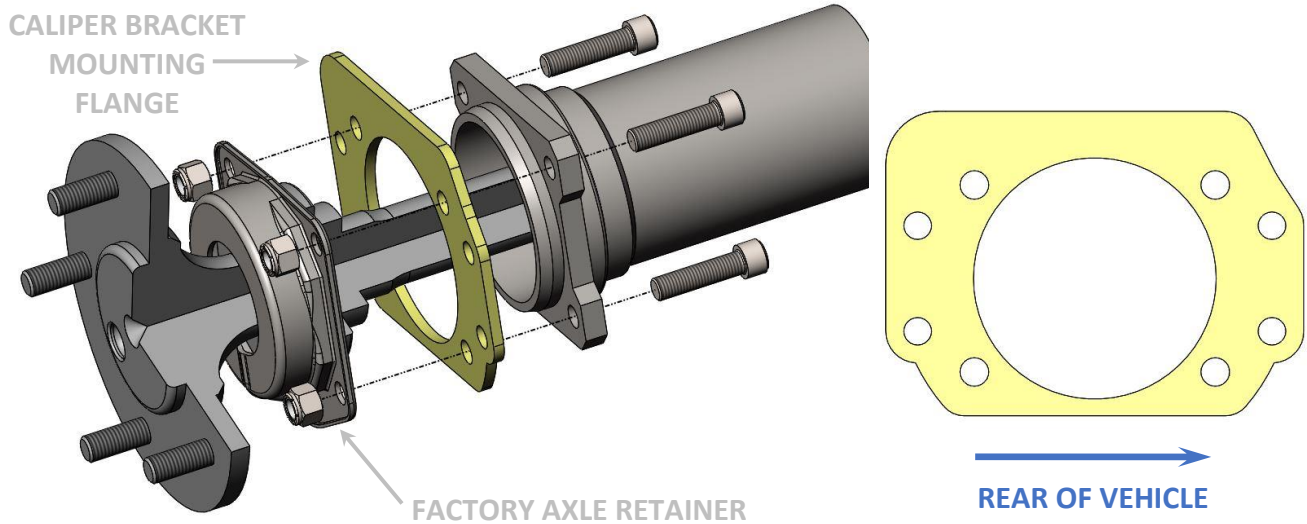

Figure 2a – Axle Installation with Caliper Bracket Mounting Flange

Figure 2b – Caliper Bracket Mounting Flange Orientation

6. The standoff of the rear axle must be determined next. This is achieved by taking the supplied depth gauge and holding it flat on the face of the axle flange. If the end of the depth gauge is flush with the back side of the previously installed Caliper Bracket Mounting Flange, your standoff is 2.500". If the end of the depth gauge is sticking past the end of the previously installed Caliper Bracket Mounting flange by .125" approximately, your axle standoff is 2.375". Refer to Figure 3 below for reference on how to measure your standoff.

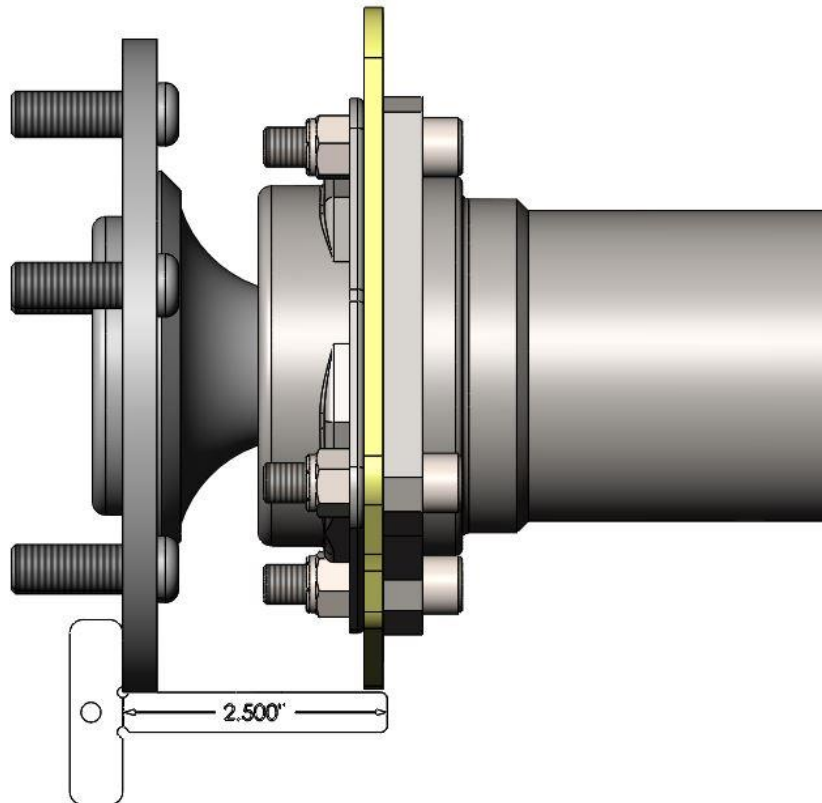

Figure 3 – Measuring Axle Standoff (2.500" Standoff Shown)

7. Install the Aluminum Caliper Mounting Bracket next. **NOTE: The Aluminum Caliper Mounting Brackets are left and right specific and designed to position the calipers towards the rear of the vehicle as shown below in Figure 4a.** If in Step 6 you determined standoff was 2.375", install the Caliper Bracket Shim Plate in between the Caliper Bracket Mounting Flange and the Aluminum Caliper Mounting Bracket as seen in Figure 4b below. If in Step 6 you determined the standoff of the axle to be 2.500", a Caliper Bracket Shim Plate is not required. Mount the Aluminum Caliper Mounting Bracket directly to the Caliper Bracket Mounting Flange as shown below in Figure 4c. **Make sure that the 2 forward most bolts go through the supplied Brake Hose Mounting Brackets.** These brackets are left and right specific and are designed so the tab faces inward to the vehicle. Use the supplied 3/8"-24 x 1.500" Socket Head Cap Screws, 3/8" AN Flat Washers, and 3/8"-24 Nylon Lock Nuts and attach the Aluminum Caliper Bracket with caliper towards the rear of the car. Torque to 40 lb/ft. Figure 4d below shows a top view of the components completely installed (2.500" Standoff).

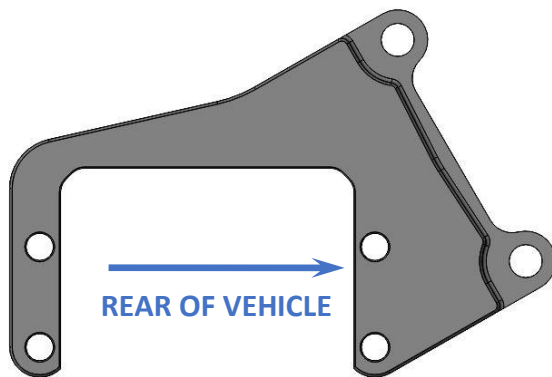

Figure 4a – Aluminum Caliper Bracket Orientation
(LH Side Shown)

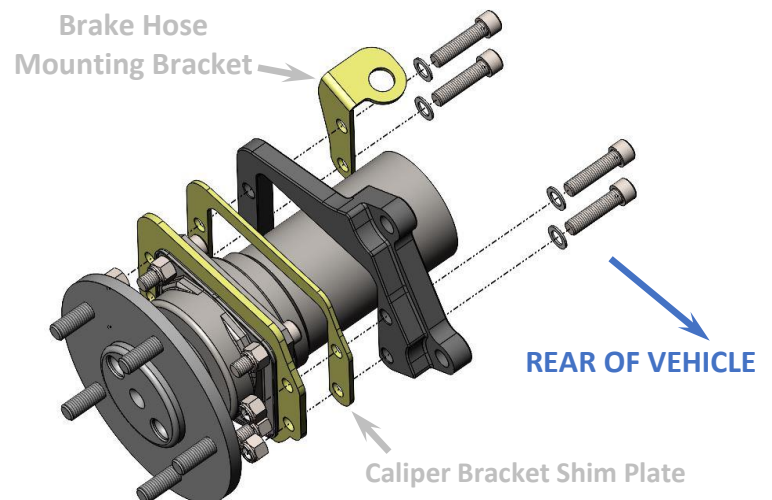

Figure 4b – Caliper Mounting Bracket Installation (2.375" STANDOFF)

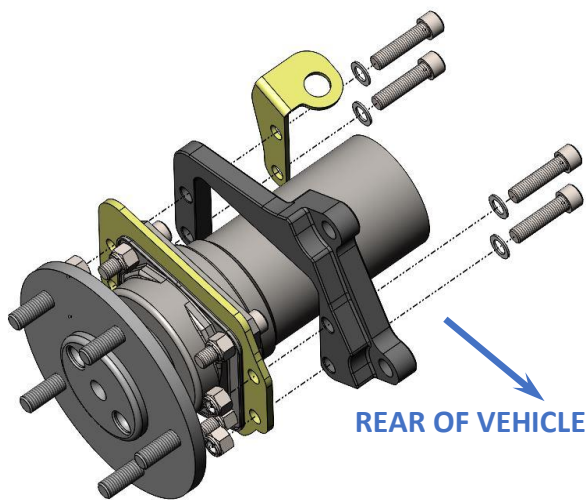

Figure 4c – Caliper Mounting Bracket Installation (2.500" STANDOFF)

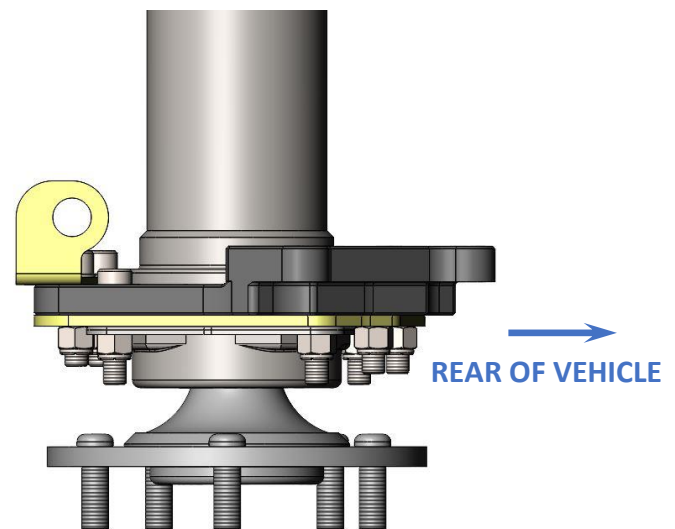

Figure 4d – TOP VIEW Aluminum Caliper Bracket Installed
(2.500" STANDOFF SHOWN)

8. Install the rotor onto the axle flange. Verify that the rotor goes all the way against the axle flange. **TIP:** To make caliper installation easier, thread a couple of flat washers and nuts against the rotor to act as a lug nut and hold everything in place. **IMPORTANT:** If using slotted and drilled rotors, pay close attention to Figure 5 on the next page for proper rotor placement on the driver and passenger side.

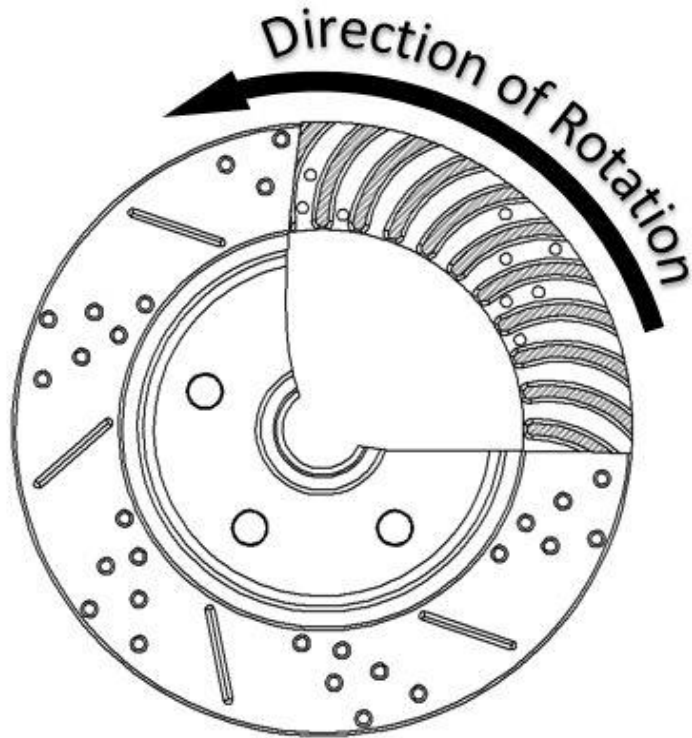

Figure 5 – Rotor Orientation

9. Remove the Caliper Anchor Bracket from the caliper along with the brake pads. Install the caliper anchor over the rotor and position against the Secondary Caliper Mounting Bracket. Use the provided M12 Flat Washers and M12-1.75 x 35mm Hex Head Bolts. **NOTE:** Do not fully tighten the bolts at this point due to possible removal for shimming. The bolts will be torqued in a later step. See Figure 6 below for reference.

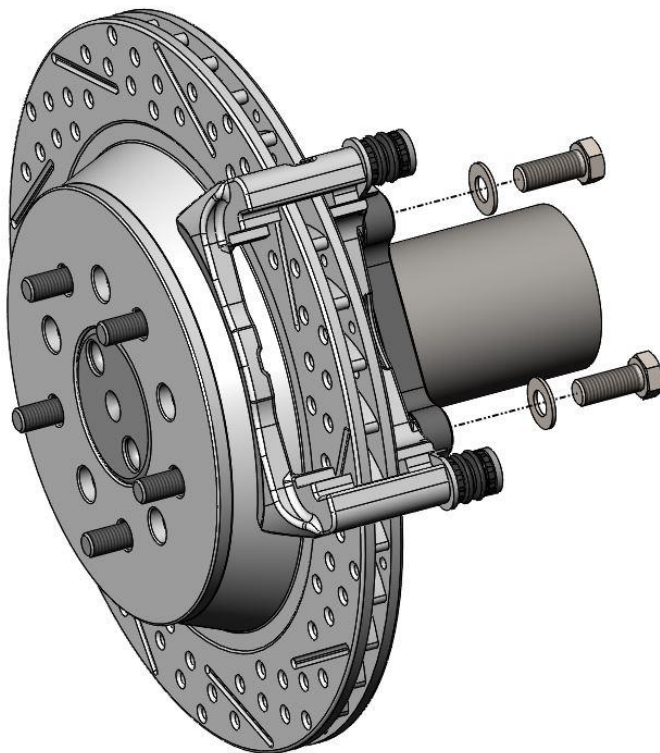

Figure 6 – Caliper Anchor Installed

10. Depending on original manufacturing tolerances, shimming of the Caliper Anchor Bracket may be required. To determine if shimming is necessary, measure between the Caliper Anchor Bracket and the brake rotor at both the outside and inside surface. See Figure 7a below for the measuring locations. Both measurements should be within .010" of each other. If they are not, using Figure 7b below for an example, calculate the necessary shim thickness. If they are not, remove the two M12-1.75 x 35mm Hex Head Bolts and place the appropriate shims between the Aluminum Caliper Mounting Bracket and the Caliper Anchor Bracket. Figure 7c below shows the proper location of the shims. With the shims installed and the Caliper Anchor Bracket centered over the rotor, torque the M12-1.75 x 35mm Hex Head Bolts to 80 lb/ft.

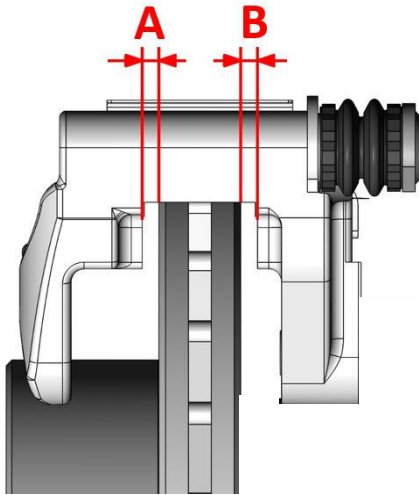

Figure 7a – Caliper Anchor Bracket Measuring Location

Shimming Process Example

$$\frac{(\text{Location A} - \text{Location B})}{2} = \text{SHIM THICKNESS NEEDED}$$

$$\frac{(.184'' - .124'')}{2} = \text{.030'' SHIM THICKNESS NEEDED}$$

Figure 7b – Shim Location Calculation Example

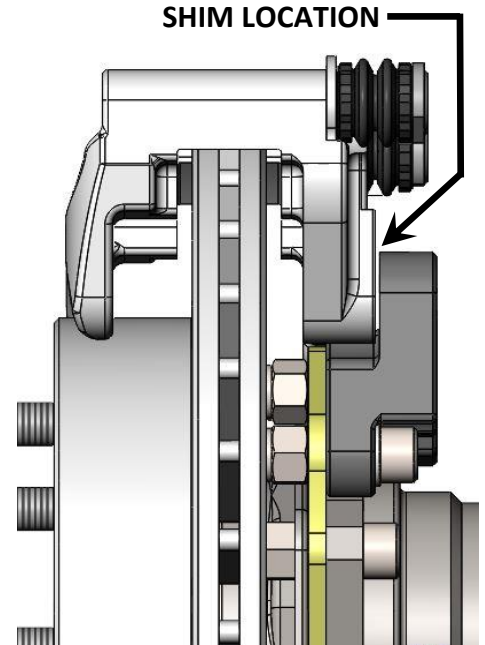

Figure 7c – Shim Location

11. Place the Stainless Steel Abutment Clips into the Caliper Anchor Bracket at this time. Refer to Figure 8a and Figure 8b Below for installation reference.

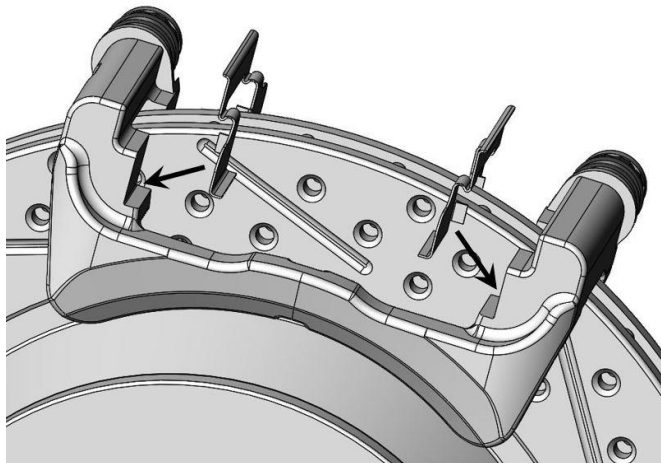

Figure 8a – Abutment Clips Installation

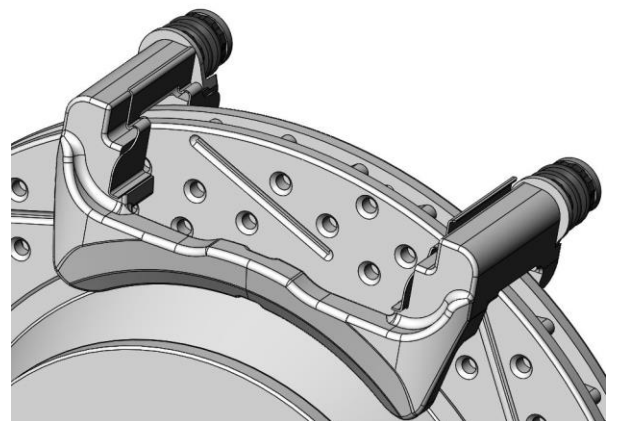

Figure 8b – Abutment Clips Installed

12. With the Abutment Clips installed, Install the pads into the Caliper Anchor Bracket. Refer to Figure 9a on the next page for reference. Once the pads are installed slide the caliper body over the brake pads and Caliper Anchor Bracket. With the caliper in place, re-install the caliper mounting bolts between the caliper and the bracket. Torque the bolts to 30 lb/ft. **IMPORTANT: Make sure that the bleeder screw is pointing upward. See Figure 9b on the next page for reference on installing the caliper.**

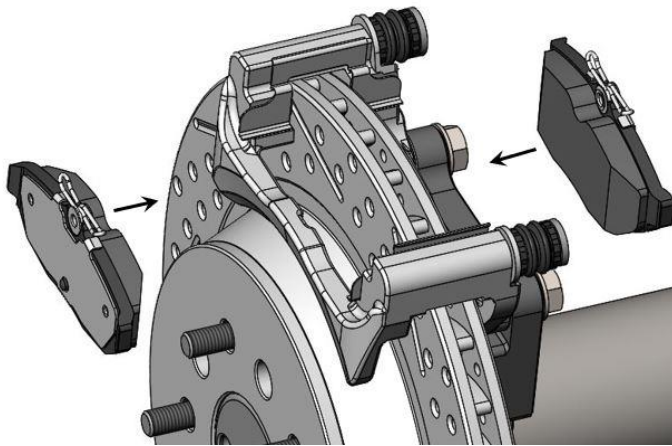

Figure 9a – Brake Pad Installation

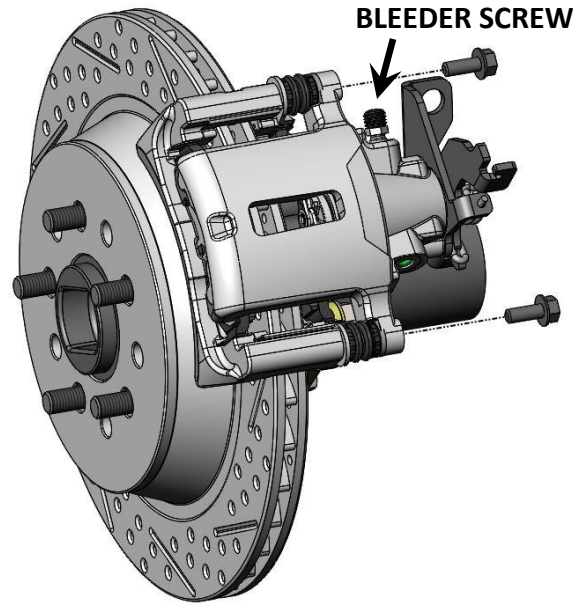

Figure 9b - Caliper Installation and Bleeder Screw Orientation

13. Install the flexible brake hose. Attach the brake hose to the caliper using the provided banjo bolt and copper crush washers as shown in Figure 10a below. Next route the hose under the axle tube and attach it to the previously installed Brake Hose Mounting Bracket with the provided clip. Attach the hardline to the brake hose. **NOTE: Depending on the location and fitting size on the OEM hardline, it may be necessary to shorten and re-flare along with slightly bending the hardline to line up properly.** Proper installation of the flexible brake hose can be seen in Figure 10b below.

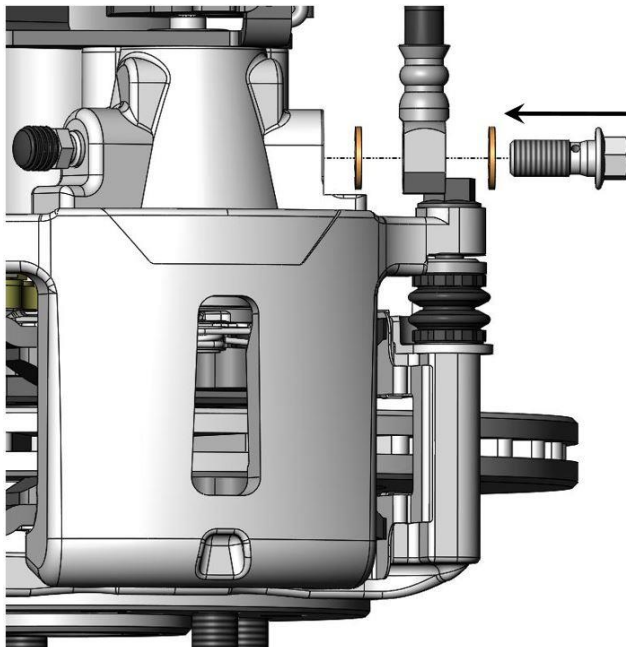

Figure 10a – Brake Hose Attachment to Caliper

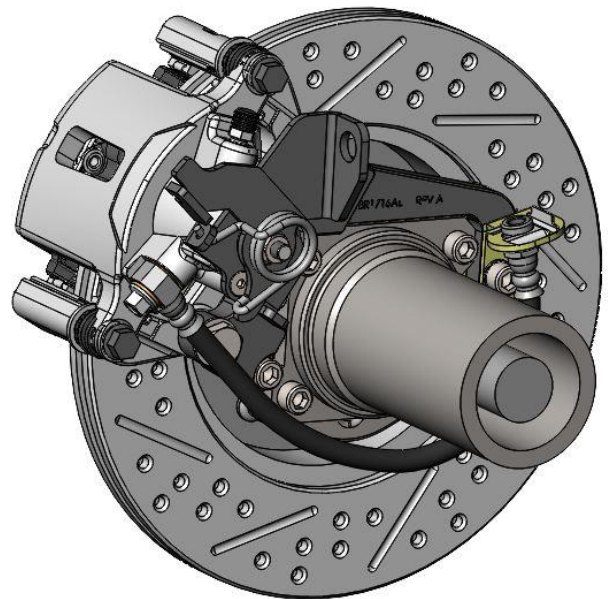

Figure 10b – Brake Hose Properly Installed

14. Once the caliper has been installed and everything is torqued to spec, it is recommended that the caliper be adjusted before installing any emergency brake cables. To do so, simply rotate the park brake lever on the caliper a couple of times. This will move the brake pads closer to the rotor and allow for adequate movement along with a proper feeling pedal.
15. With the caliper adjusted, attach the emergency brake to the caliper. If using the Master Power Brakes Universal Emergency Brake Cable Kit (p/n: HWC2500) shown below in Figure 11, please follow the instructions included with the cables. If obtaining cables from a different source, please follow the instructions for those cables. Once the cables are installed, please verify that there isn't excessive drag caused by the cables and caliper adjustment. Also, please verify that there isn't excessive movement or travel within the cables.



Figure 11 – Universal Emergency Brake Cable Kit (p/n: HWC2500)

16. Once everything is installed and pre-adjustments have been made, bleed the brakes and re-install the wheels and tires.
17. Installation is now complete.

If you have any questions regarding installation, feel free to contact us!

 MASTER POWER BRAKES 	
PHONE NUMBERS	
Local: (704)-664-8866	
Toll Free: (888)-351-8781	
Fax: (704)-664-8862	
WEBSITE	
www.mpbrakes.com	
ADDRESS	
110 Crosslake Park Dr. Mooresville, NC 28117	
SOCIAL MEDIA	
 Instagram	@masterpowerbrakes
 facebook	www.facebook.com/mpbrakes