



MASTER POWER BRAKES



13" Rear Disc Brake Conversion Kit

57-64 Pontiac

P/N: DB3718BR

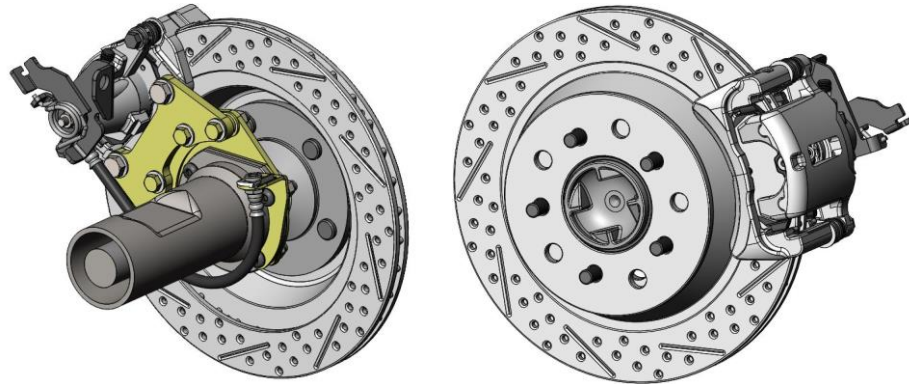

Thanks for your purchase of our Legend HP Plus Series Rear Disc Brake Conversion Kit for 57-64 Full-size Pontiacs. This system does require modifications to the rear axle flanges and uses basic hand tools to install. The system is designed to take place of your current drum brake system and replace it with a simple disc brake system.

*****IMPORTANT*****

This kit requires the use of at least 17" wheels for clearance and this kit has a 5 x 5.000" bolt pattern

Installation Notes:

- Please read all instructions before attempting the installation.
- Proper operation of your brakes is essential for your safety and the safety of others. Any brake service should be performed by a professional technician experienced in the installation of brake systems.
- Any installation requiring you to remove a wheel or gain access under the vehicle requires use of jack stands or a lift appropriate to the weight of the vehicle. In all cases, recommended ratings for jack stands should be at least 2-tons. If using a floor jack, be sure to use the appropriate wheel chocks.
- All installations require proper safety procedures and protective eyewear.
- A selection of hand tools sufficient to engage in the installation of these products is assumed and is the responsibility of the installer to have in his/her possession prior to beginning this installation. All installations, which require removal of hydraulic hoses and/or bleeding of the brakes, require appropriate fitting/line wrenches, as well as a safety catch can and protective eyewear. Other than these items, if unique or special tools are required they are listed in the section for that step.
- **ALWAYS CONFIRM WHEEL FITMENT PRIOR TO BEGINNING THE INSTALLATION OF ANY BRAKE SYSTEM!!** Returns will not be accepted for ANY installed part or assembly. Use great care to prevent cosmetic damage when performing wheel fit check!
- Before starting the installation, verify that all parts are included with the brake kit. If items are missing, notify Master Power Brakes immediately.
- Master Power Brakes recommends the use of a high quality DOT 3 or DOT 4 brake fluid. **ALL WARRANTY IS VOID IF DOT 5 FLUID IS USED.**

Parts List	
Quantity	Description
1	Driver Side Caliper (Includes brake pads and Caliper Anchor Bracket)
1	Passenger Side Caliper (Includes brake pads and Caliper Anchor Bracket)
1	Left 13" Drilled, Slotted, & Zinc Washed Brake Rotor
1	Right 13" Drilled, Slotted, & Zinc Washed Brake Rotor
2	Primary Caliper Mounting Bracket
2	Secondary Caliper Mounting Bracket
2	Caliper Bracket Shim Plate
1	Axle Standoff Depth Gauge (Raw Steel)
2	Axle Flange Spacer Plate
4	M12-1.75 x 30mm Socket Head Cap Screws
4	M12 Flat Washers
8	3/8"-24 x 1.750" Grade 8 Hex Head Bolt
8	3/8"-24 Nyloc Lock Nut
16	3/8" SAE Flat Washers
8	Modified 3/8"-16 x 1.500" Button Head Bolts
8	3/8"-16 Nyloc Lock Nuts
8	3/8" AN Flat Washers
8	Spacer Bushing (.375" ID x .750" OD x .231" Thick)
2	Axle Centric Ring
1	Hose Kit (14" Hoses w/10mm Banjo Bolt & Hardware)
1	Left Brake Hose Mounting Bracket
1	Right Brake Hose Mounting Bracket

Replacement Parts	
Brake Pads	FMSI No: 1082

Installation:

1. With the vehicle properly supported, remove the rear wheels and tires.
2. Removing the factory drum brake assembly is required next. With the drum removed, remove the axle shafts from the axle housing. With the axle shafts removed, remove the remaining drum brake components such as the shoes and backing plates.
3. At this time, clean the axle shaft thoroughly and inspect the axle bearings and axle housing for any excessive wear. **IMPORTANT: The factory axle retainer must be removed from the axle shaft.**
4. The outer diameter of the axle flange can be no larger than 6.875" in outside diameter. This is critical for proper fitment of the rotor over the axle flange. For axles with a flange larger than 6.875", using a lathe, machine the outer flange down to the necessary diameter of 6.875". See Figure 1 below for measuring reference.

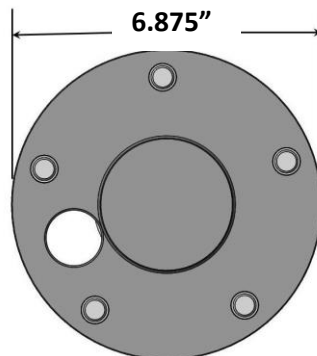

Figure 1 – Measuring the Axle Flange

- From the backside of the axle flange, insert the provided Modified 3/8"-16 x 1.500" Button Head Bolts into the axle housing. Make sure that the 2 forward most bolts go through the supplied Brake Hose Mounting Brackets. **NOTE: These brackets are left and right specific and are designed so the tab faces inward to the vehicle.** Once installed, position the Axle Flange Spacer Plate over the four bolts against the axle flange. See Figures 2a and 2b below for installation reference.

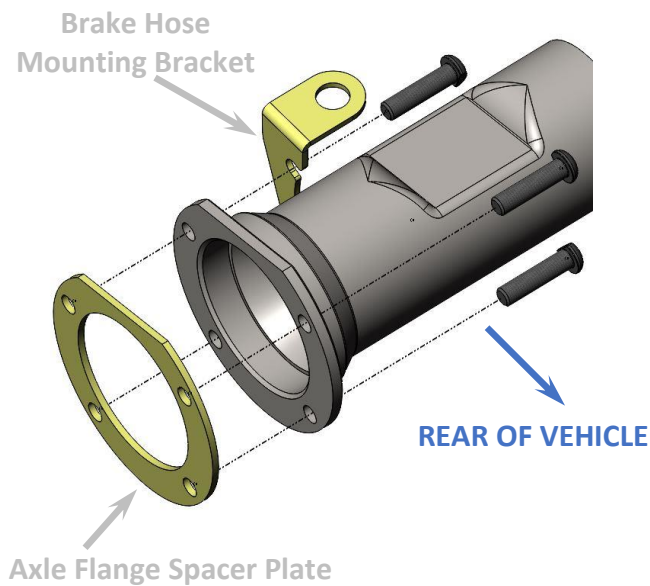

Figure 2a– Axle Flange Spacer Plate Installation

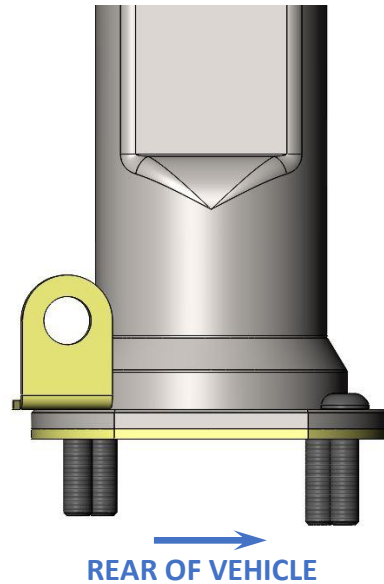

Figure 2b– TOP VIEW Axle Flange Spacer Plate Installed

- Reinstall the axle shaft into the housing. Follow this by installing the Primary Caliper Mounting Bracket over the previously installed Modified 3/8"-16 x 1.500" Button Head Bolts. Once everything is in place, install the 3/8" AN Flat Washers and 3/8"-16 Nyloc Lock Nuts and tighten to 40 lb/ft. **NOTE: The Primary Caliper Brackets are left and right specific and designed to position the calipers towards the rear of the vehicle.** See Figure 3a and Figure 3b below for bracket orientation and installation.

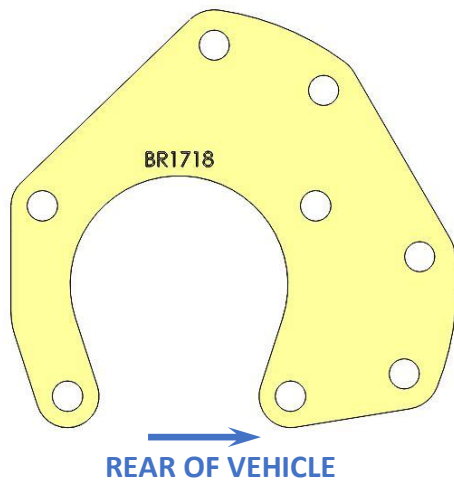

Figure 3a – Caliper Bracket Orientation
(LH Side Shown)

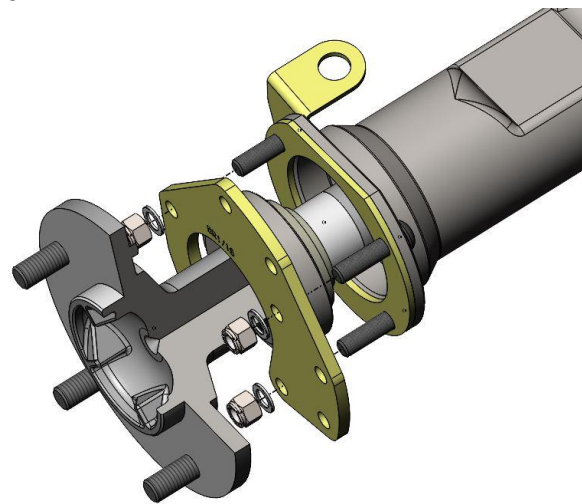

Figure 3a– Primary Caliper Mounting Bracket Installation

- The standoff of the rear axle must be determined next. This is achieved by taking the supplied depth gauge and holding it flat on the face of the axle flange through the axle access hole. If the end of the depth gauge is touching or very close to the axle tube flange, your standoff is 2.810". If the end of the depth gauge is approximately .100" away from the axle tube flange, your axle standoff is 2.910". Refer to Figure 4a and Figure 4b on the next page or reference on how to measure your standoff.

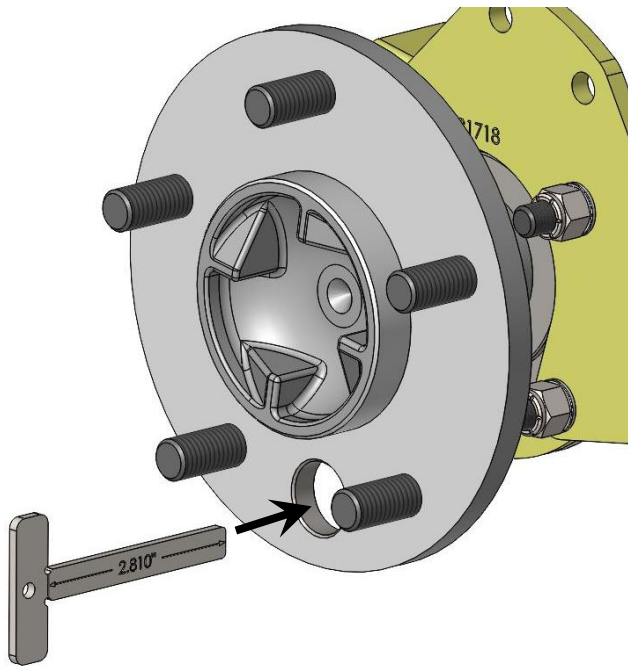

Figure 4a – Measuring Axle Standoff (2.810" Standoff Shown)

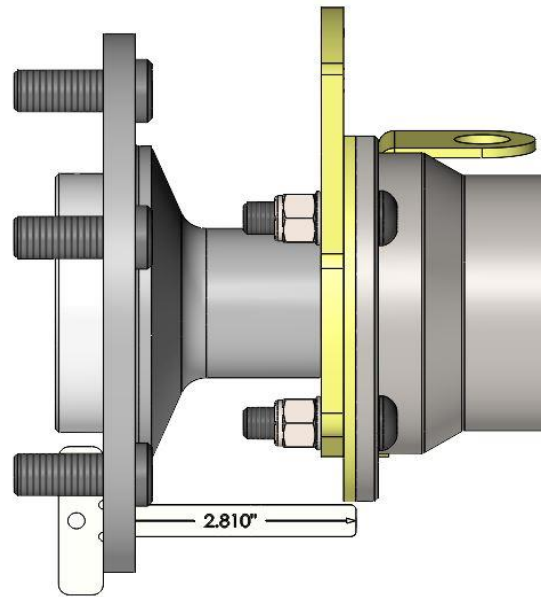

Figure 4b – Measuring Axle Standoff (2.810" Standoff Shown)

8. Install the Secondary Caliper Mounting Bracket at this time. If in step 7 you determined your standoff was 2.810", install the Caliper Bracket Shim Plate between the Primary Caliper Mounting Bracket and the spacer bushings as seen in Figure 5a below. If in step 7 you determined your standoff was 2.910", the Caliper Bracket Shim Plate is not required. Mount the Secondary Caliper bracket to the Primary Caliper Bracket with the spacer bushings only between them, as seen in Figure 5b below. Use the provided 3/8"-24 x 1.750" Grade 8 Hex Head Bolts, 3/8" SAE Flat Washers, 3/8"-24 Nyloc Nuts while installing the Secondary Caliper Mounting Bracket. Once in position, torque the 3/8" hardware to 40 lb/ft.

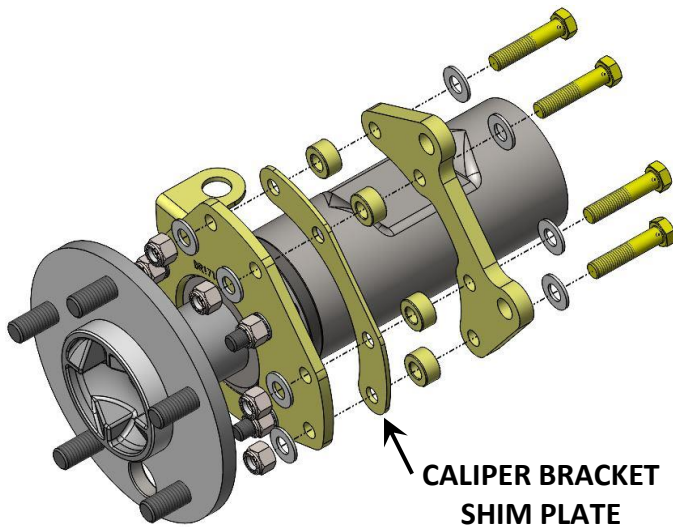

Figure 5a – Caliper Mounting Bracket Installation (2.810" Standoff)

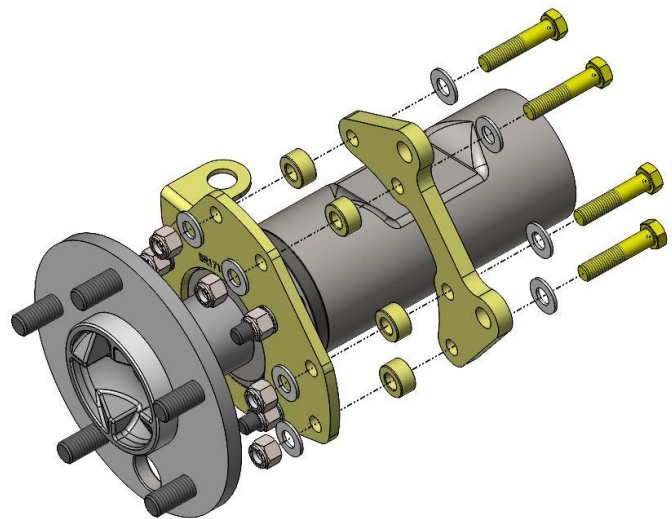

Figure 5b – Caliper Mounting Bracket Installation (2.910" Standoff)

9. Install the rotor onto the axle flange. A Centric Ring is provided to center the rotor onto the axle shaft. Place the Centric Ring over the axle hub register. To allow the Centric Ring to go all the way against the axle shaft flange, it may be necessary to clean the hub register with a wire brush or emery cloth. Once the Centric Ring is in place, slide the rotor over the studs against the axle flange. Verify that the rotor goes all the way against the axle flange. Figure 6a on the next page shows the proper sequence. **TIP:** To make caliper installation easier, thread a couple of flatwashers and nuts against the rotor to act as a lug nut and hold everything in place. **IMPORTANT:** If using slotted and drilled rotors, pay close attention to Figure 6b on the next page proper rotor placement on the driver and passenger side.

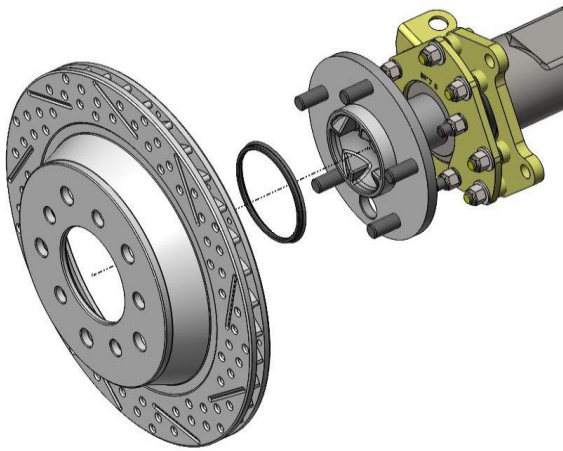

Figure 6a – Rotor and Centering Ring Installation

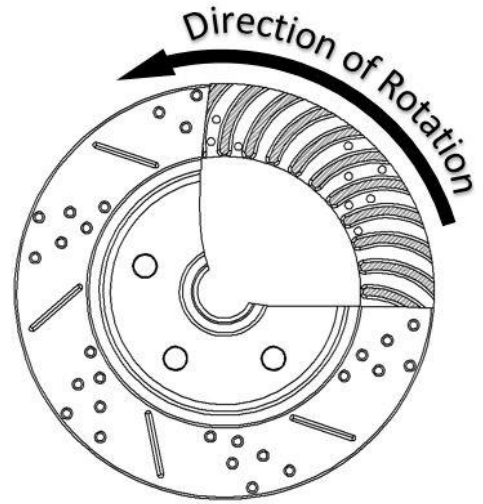

Figure 6b – Rotor Orientation

- Remove the Caliper Anchor bracket from the caliper by removing the M8-1.25 x 21mm Caliper Mounting Bolts from the Anchor followed by removing the brake pads. Install the caliper anchor over the rotor and position to the Secondary caliper bracket. Using the provided M12 Flat Washers and M12-1.75 x 30mm Socket Head Cap Screws, and torque the bolts to 80 lb/ft. Refer to Figure 7 below for reference on installing the caliper anchor.

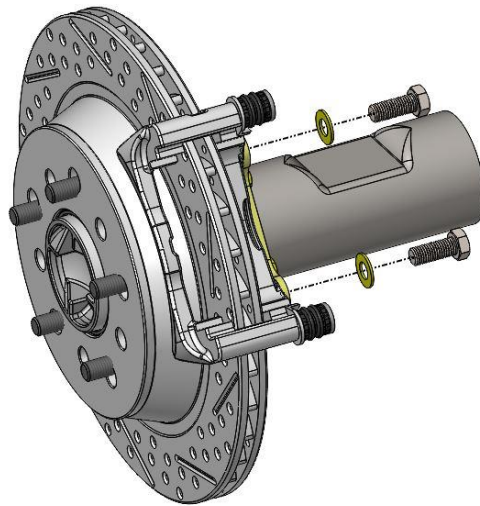

Figure 7 – Caliper Anchor Installation

- Place the Stainless-Steel Abutment Clips into the Caliper Anchor Bracket at this time. Refer to Figure 8a and Figure 8b below for installation reference.

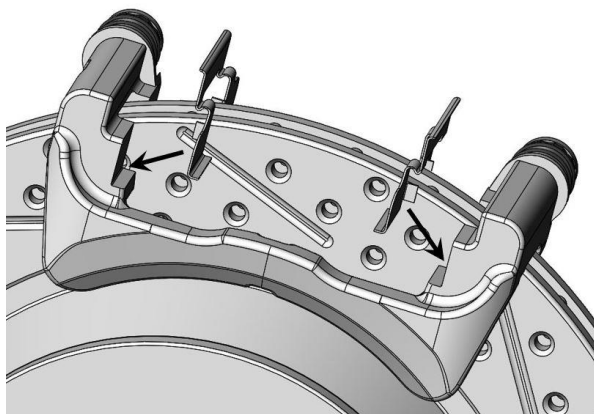

Figure 8a– Abutment Clips Installation

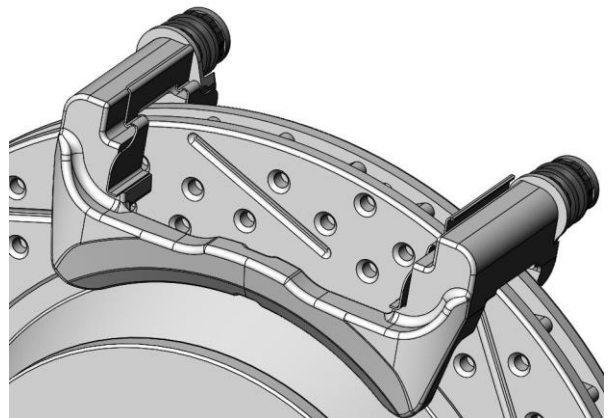

Figure 8b – Abutment Clips Installed

12. With the Abutment Clips installed, Install the pads into the Caliper Anchor Bracket. Refer to Figure 9a below for reference. Once the pads are installed slide the caliper body over the brake pads and Caliper Anchor Bracket. With the caliper in place, re-install the caliper mounting bolts between the caliper and the bracket. Torque the bolts to 30 lb/ft. **IMPORTANT:** Make sure that the bleeder screw is pointing upward. See Figure 9b below for reference on installing the caliper.

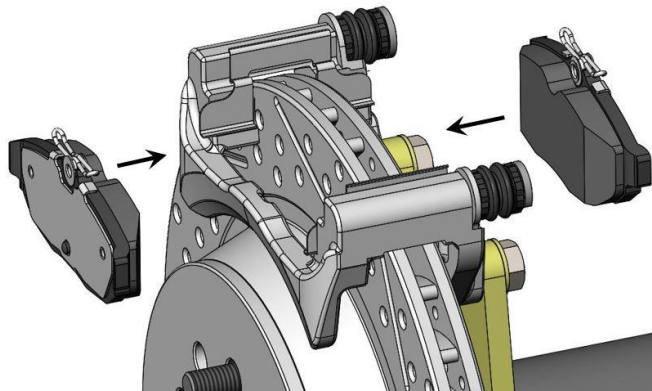

Figure 9a – Brake Pad Installation

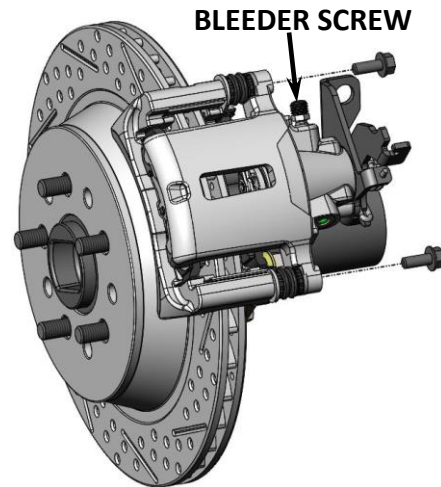

Figure 9b - Caliper Installation and Bleeder Screw Orientation

13. Install the flexible brake hose. Attach the brake hose to the caliper using the provided banjo bolt and copper crush washers as shown in Figure 10a below. Next route the hose under the axle tube and attach it to the previously installed Brake Hose Mounting Bracket with the provided clip. Attach the hardline to the brake hose. **NOTE: Depending on the location and fitting size on the OEM hardline, it may be necessary to shorten and re-flare along with slightly bending the hardline to line up properly.** Proper installation of the flexible brake hose can be seen in Figure 10b below.

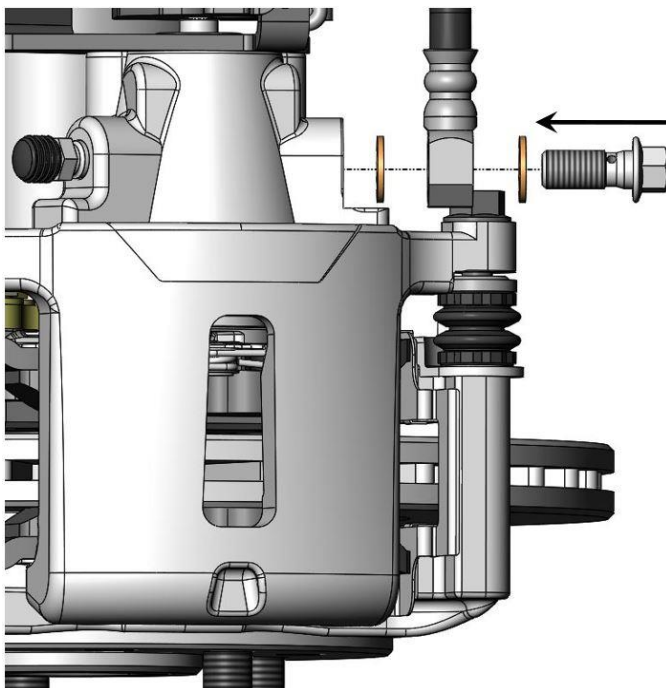

Figure 10a – Brake Hose Attachment to Caliper

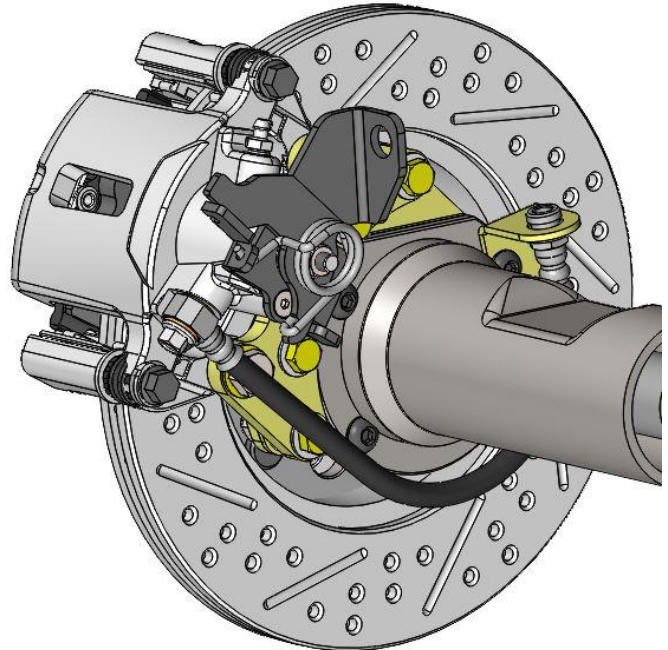

Figure 10b – Brake Hose Attached at the Rear Axle Housing

14. Once the caliper has been installed and everything is torqued to spec, it is recommended that the caliper be adjusted before installing any emergency brake cables. To do so, simply rotate the park brake lever on the caliper a couple of times. This will move the brake pads closer to the rotor and allow for adequate movement along with a proper feeling pedal.

15. With the caliper adjusted, attach the emergency brake to the caliper. If using the Master Power Brakes Universal Emergency Brake Cable Kit (p/n: HWC2500) shown below in Figure 11, please follow the instructions included with the cables. If obtaining cables from a different source, please follow the instructions for those cables. Once the cables are installed, please verify that there isn't excessive drag caused by the cables and caliper adjustment. Also, please verify that there isn't excessive movement or travel within the cables.



Figure 11 – Universal Emergency Brake Cable Kit (p/n: HWC2500)

16. Once everything is installed and pre-adjustments have been made, bleed the brakes and re-install the wheels and tires.

17. Installation is now complete.

If you have any questions regarding installation, feel free to contact us!

 MASTER POWER BRAKES 
PHONE NUMBERS
Local: (704)-664-8866 Toll Free: (888)-351-8781 Fax: (704)-664-8862
WEBSITE
www.mpbrakes.com
ADDRESS
110 Crosslake Park Dr. Mooresville, NC 28117
SOCIAL MEDIA
 Instagram @masterpowerbrakes
 facebook www.facebook.com/mpbrakes