



**Master Power Brakes  
Combination Valve Kit  
Various Universal Applications  
p/n: VL3359K**



Thanks for the purchase of the Master Power Brakes Universal Combination Valve for disc/disc applications. This is a universal product that can be installed on many different vehicles. The kit includes all of the necessary components to install it in a vehicle.



Would you like to see one of our on-line videos on this product?  
Visit [www.mpbrakes.com/videos](http://www.mpbrakes.com/videos)

Included Parts	
Quantity	Description
1	Combination Valve (p/n: VL3359)
1	Universal Mounting Bracket (p/n: BR1261A)
1	Switch Connector (p/n: HW1709)
1	Bleeder Tool (p/n: HW3350)
1	Nut – 7/16"-24 x 3/16" Line
1	Nut – 1/2"-20 x 3/16" Line
2	Nut – 3/8"-24 x 3/16" Line
1	Nut – 9/16"-18 x 1/4" Line
2	Coupler – 3/8"-24 x 3/8"-24
2	Coupler – 7/16"-24 x 7/16"-24
1	Tee Fitting – 3/8"-24
1	3/8"-24 Inverted Flare Plug
2	Adapter – 7/16"-24 Female x 3/8"-24 Male
1	Adapter – 9/16"-18 Male x 3/8"-24 Female
1	5/16"-18 x 1.750" Hex Head Bolt
1	5/16"-18 Serrated Flange Nut

A disc/disc combination valve has two major components, a pressure differential switch and a rear brake proportioning valve. See below for further explanation:

### **Proportioning Valve (A)**

Many people refer to the Combination Valve as the Proportioning Valve but that is not actually correct. The Proportioning Valve is actually a standalone portion of the Combination Valve. This is located within the rear portion of the Combination Valve and its function is to eliminate a high pressure spike to the rear brakes causing the rear brakes to lock up quicker than the front and therefore causing the car to spin out. Under normal braking scenarios, the Proportioning Valve is just along for the ride allowing the pressure that the master cylinder makes pass right to the rear brakes. In a panic braking situation is where the Proportioning Valve does its work. When panic stopping, the valve will regulate pressure to the rear at a pre-set pressure and should prevent rear wheel lock up and the car spinning out.

### **Pressure Differential Valve & Switch (B)**

A safety feature built into the Combination Valve is the Pressure Differential Valve & Switch located in the center of the Combination Valve. Should the brake system lose pressure on the front or rear half of the system, this valve will move in one direction or the other and block the portion that has lost pressure. When that happens, the switch is grounded and can then activate a trouble light on the dash. It is not necessary to use the switch but it is recommended. When this valve moves, it is commonly referred to as being "tripped". The procedure for un-tripping the valve is explained later.

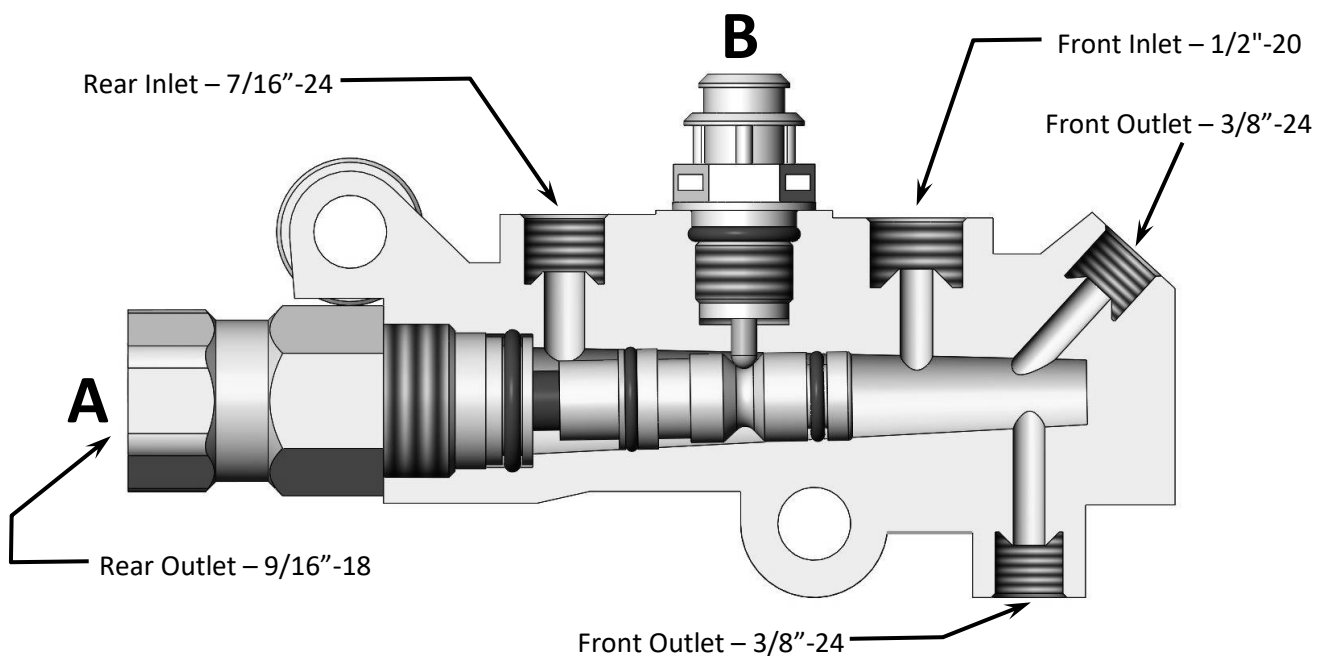

### **Installation Notes:**

- As seen above, there are two ports that are designated as front brakes. The valve can be plumbed using both ports or just one of the two ports. **IMPORTANT:** Both ports do not have to be used. Pick the one or both that best suits you and your vehicles situation. If using just one of the ports, be sure to plug the remaining port with the provided 3/8\"-24 Inverted Flare Plug.
- The valve can be mounted in most any situation and there isn't a good or bad place in regards to under the master cylinder, on the inner fenderwell or on the frame. The only requirement is that the valve be below

the ports on the master cylinder. Mounting above the master cylinder will lead to air being trapped in the system.

- Included with the kit is a tool used for keeping the Pressure Differential Valve centered while bleeding the brakes. Not using this tool is the leading cause of the valve becoming “tripped”. Follow the steps below for using the Bleeder Tool:
  1. Remove the installed Pressure Differential Switch. Figure 1a shows the switch before removal.
  2. Thread the tool into the Combination Valve as seen in Figure 1b. **NOTE:** Do not force the tool in place. If it won't thread into place, it is possible that the valve is not centered and will need to be centered before installing.
  3. Bleed the brakes.
  4. Remove the tool and replace with the previously removed switch. **IMPORTANT:** The Pressure Differential Valve is sealed so no fluid will be lost when removing the tool.

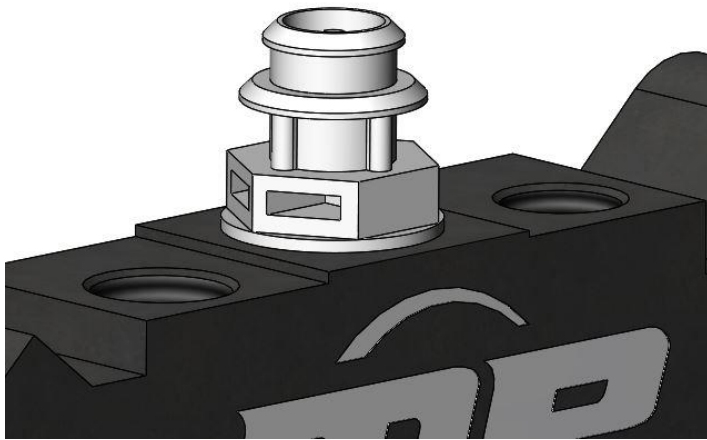

Figure 1a – Switch Installed in the Combination Valve

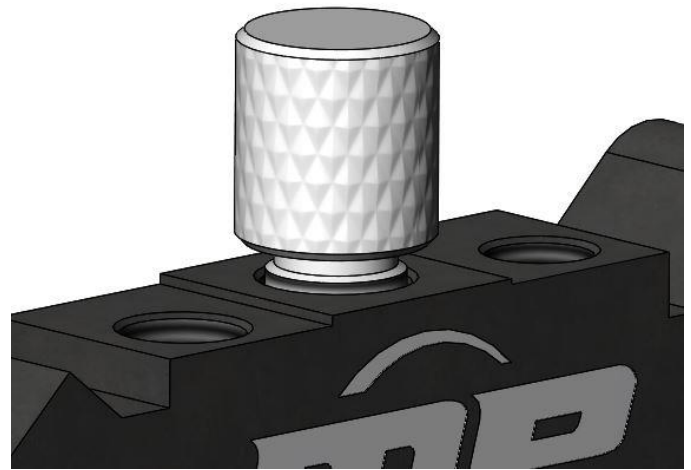

Figure 1b – Tool Installed in the Combination Valve

- To determine if the Pressure Differential Valve has “tripped” and to re-center the valve, follow the steps below:
  1. Use a test light attached to the positive battery post or a constant 12-volt source.
  2. Place the tip of the test light on the center pin of the switch.
  3. If the test light does not turn on, the valve has not tripped.
  4. If the light turns on, the valve has tripped. Remove the switch from the Combination Valve and follow the steps listed below to center a tripped valve:
    - a) Determine whether the valve has pushed to the front or the rear (only one side should have fluid pressure).
    - b) If the valve has tripped blocking front pressure, you will center the valve with the rear part of the system. If the valve has tripped blocking rear pressure, the front of the system will be used to center.
    - c) Open a bleeder at the front or rear and gently press down on the pedal applying steady pressure. Close the bleeder at the bottom of the pedal. Continue this until the valve moves and re-centers itself. **NOTE:** This can take several times.
    - d) Once the valve has been centered, bleed the entire system. Be sure to put the Bleeding Tool in place to avoid the same complication.

If you have any questions or comments, please call Master Power Brakes at (888) 533-1199.