



Master Power Brakes

Master Cylinder to Combo Valve Lines

64-66 Ford Mustang (when using BM15201-1)
p/n: LN15201-1

Included Parts	
Quantity	Description
1	Rear Hardline (p/n: LNMP0011) 9/16"-18 Fitting - OLIVE 7/16"-24 Fitting - RED
1	Front Hardline (p/n: LNMP0012) 1/2"-20 Fitting - GREEN 1/2"-20 Fitting - GREEN
1	Combination Valve to Inner Fender Mounting Template

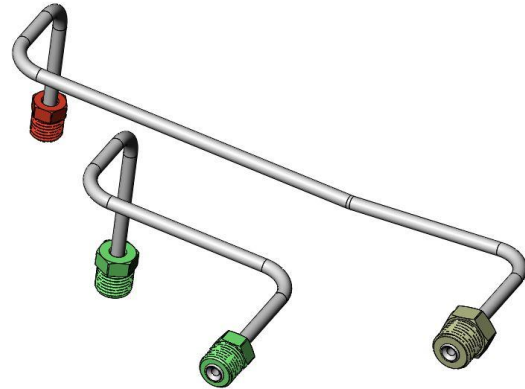

Installation Instructions:

1. Place the cut-out Combination Valve template on the driver side inner fender by locating it with the lower two hood hinge bolts. If the hood hinge and bolts are currently on the car, cut out around the dashed lines on the template. This will allow the template to go over the heads of the bolts and set flat on the inner fender. If the hood hinge and bolts are not installed, locate the template with the center marks on the template and the center points of the lower two hood hinge bolts. Tape template in place to ensure that it doesn't move. See Figure 1 below for further reference.

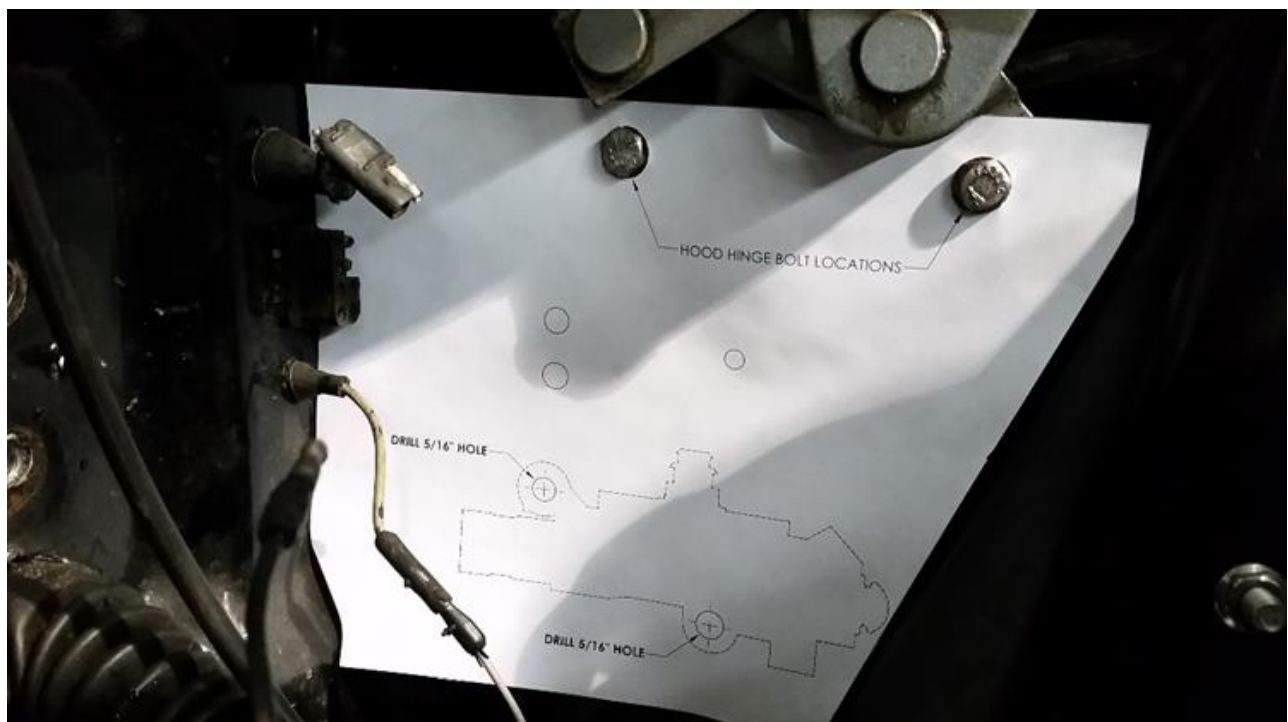

Figure 1 – Combination Valve Template Location

- Using a center punch, mark both 5/16" holes that are shown on the Combination Valve template. Once the holes have been marked, use a 5/16" drill bit and drill the 2 holes.
- Once both holes have been drilled and template has been removed from the inner fender, loosely attach the Combination Valve to the inner fender using the supplied 5/16"-18 X 1.750" Hex Head Bolts and Serrated Flange Nuts. **NOTE:** Leaving these bolts slightly loose at this point will help installation of the lines. Figure 2 below shows the valve installed on the inner fender.



Figure 2 – Combination Valve Location

- Attach both pre-bent brake lines to the Combination Valve. Once both fittings on each line are installed, tighten the two mounting bolts for the combination to 18 lbs/ft valve followed by the tightening of each fitting until fully seated. For reference on line routing, see Figure 3 Below.



Figure 3 – Brake Line Routing

- Additional plumbing will need to be performed to adapt your factory front and rear brake lines to the ports of our Combination Valve.
- Installation complete.

If you have any questions or comments, please call Master Power Brakes at (888) 533-1199.

64-66 Ford Mustang w/ use of:

- LN15201-1
- LN15210
- LNMUS6466K

ϕ .580

**HOOD HINDGE
BOLTS**

**CUT ALONG
BOLD LINE**

**DRILL 5/16"
HOLE**

**DRILL 5/16"
HOLE**



Use provided ruler to
verify template has
printed to scale

